

# **Theory of Machines**

## Mechanism and Machines

**Mechanism:** If a number of bodies are assembled in such a way that the motion of one causes constrained and predictable motion to the others, it is known as a mechanism. A mechanism transmits and modifies a motion.

**Machine:** A machine is a mechanism or a combination of mechanisms which, apart from imparting definite motions to the parts, also transmits and modifies the available mechanical energy into some kind of desired work.

It is neither a source of energy nor a producer of work but helps in proper utilization of the same.

The motive power has to be derived from external sources.

A slider - crank mechanism converts the reciprocating motion of a slider into rotary motion of the crank or vice versa.

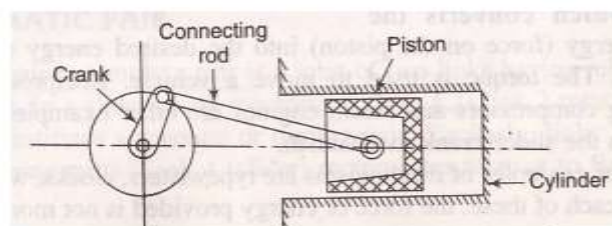

Figure-1

(Available) force on the piston  $\rightarrow$  slider crank + valve mechanism  $\rightarrow$  Torque of the crank shaft (desired).

Examples of slider crank mechanism  $\rightarrow$  Automobile Engine, reciprocating pumps, reciprocating compressor, and steam engines.

Examples of mechanisms: type writer, clocks, watches, spring toys.

**Rigid body:** A body is said to be rigid if under the action of forces, it does not suffer any distortion.

Resistant bodies: Those which are rigid for the purposes they have to serve.

Semi rigid body: Which are normally flexible, but under certain loading conditions act as rigid body for the limited purpose.

Example: 1. Belt is rigid when subjected to tensile forces. So belt-drive acts as a resistant body. 2. Fluid is resistant body at compressive load.

Link: A resistant body or a group of resistant bodies with rigid connections preventing their relative movement is known as a link.

A link may also be defined as a member or a combination of members of a mechanism, connecting other members and having motion relative to them.

A link is also known as kinematic link or element.

Links can be classified into binary, ternary, quarternary, etc, depending upon their ends on which revolute or turning pairs can be placed.



Figure-2

Kinematic pair:

A kinematic pair or simply a pair is a joint of two links having relative motion between them.

Types of kinematic pairs: Kinematic pairs can be classified according to

- (i) Nature of contact
- (ii) Nature of mechanical constraint
- (iii) Nature of relative motion

Kinematic pairs according to nature of contact

- (a) Lower pair: A pair of links having surface or area contact between the members is known as a lower pair. Example: – Nut and screw, shaft rotating in bearing, all pairs of slider crank mechanism, universal joint etc.
- (b) Higher pair: When a pair has a point or line contact between the links, it is known as a higher pair. Example: – Wheel rolling on a surface, cam and follower pair, tooth gears, ball and roller bearings.

### Kinematic pairs according to nature of mechanical constraint

- (a) Closed pair : When the elements of a pair are held together mechanically, it is known as a closed pair. The contact between the two can be broken only by destruction of at least one of the member.
- (b) Unclosed pair : When two links of a pair are in contact either due to force of gravity or some spring action, they constitute an unclosed pair.

### Kinematic pairs according to nature of relative motion:

- (a) Sliding pair: If two links have a sliding motion relative to each other, they form a sliding pair.
- (b) Turning pair: When one link has a turning or revolving motion relative to the other, they constitute a turning or revolving pair.
- (c) Rolling Pair: When the links of a pair have a rolling motion relative to each other, they form a rolling pair.
- (d) Screw pair: If two mating links have a turning as well as sliding motion between them, they form a screw pair. Ex – lead screw and nut.
- (e) Spherical pair: When one link in the form of a sphere turns inside a fixed link, it is a spherical pair. Ex – ball and socket joint.

### Degrees of freedom:

An unconstrained rigid body moving in space can describe the following independent motions.

1. Translational motion along any three mutually perpendicular axes  $x$ ,  $y$ ,  $z$  and
2. Rotational motions about these axes. Thus, a rigid body possesses six degrees of freedom.

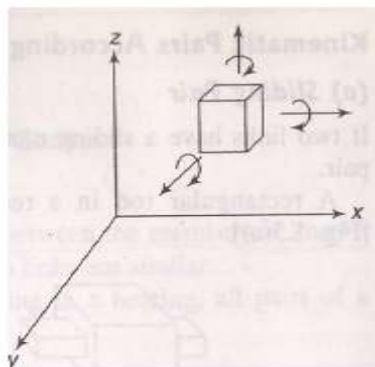

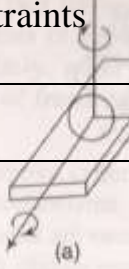
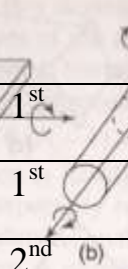
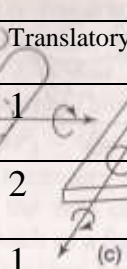

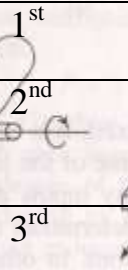
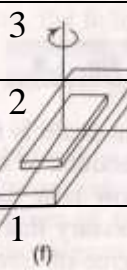

Figure - 3

Degrees of freedom of a pair are defined as the number of independent relative motions both translational and rotational. A pair in space can have,

$$\text{DOF} = 6 - \text{number of restraints.}$$

Classification of kinematic pairs:

Depending upon the number of restraints imposed on the relative motion of the two links connected together, a pair can be classified as

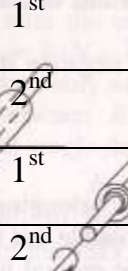
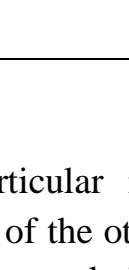
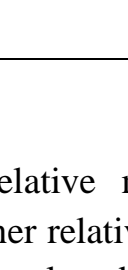
Class	Number of restraints	Form	Restraint on		Kinematic pair	Figure - 4
			Translatory	Rotary		
I	1	 1 <sup>st</sup>	1	0	Sphere – plane	a
II	2	 1 <sup>st</sup>	2	0	Sphere – cylinder	b
		 2 <sup>nd</sup>	1	1	Cylinder – plane	c
III	3	 1 <sup>st</sup>	3	0	Spheric	d
		 2 <sup>nd</sup>	2	1	Sphere – slotted cylinder	e
		 3 <sup>rd</sup>	1	2	Prism – plane	f
IV	4	 1 <sup>st</sup>	3	1	Slotted – spheric	g
		 2 <sup>nd</sup>	2	2	Cylinder – cylinder	h
V	5	 1 <sup>st</sup>	3	2	Cylinder – collar	i
		 2 <sup>nd</sup>	2	3	Prismatic bar in prismatic hole	j

A particular relative motion between two links of a pair must be independent of the other relative motions that the pair can have. A screw and nut pair permits translational and rotational motions. However as the two motion cannot be accomplished independently, a screw and nut pair is a kinematic pair of the fifth class.

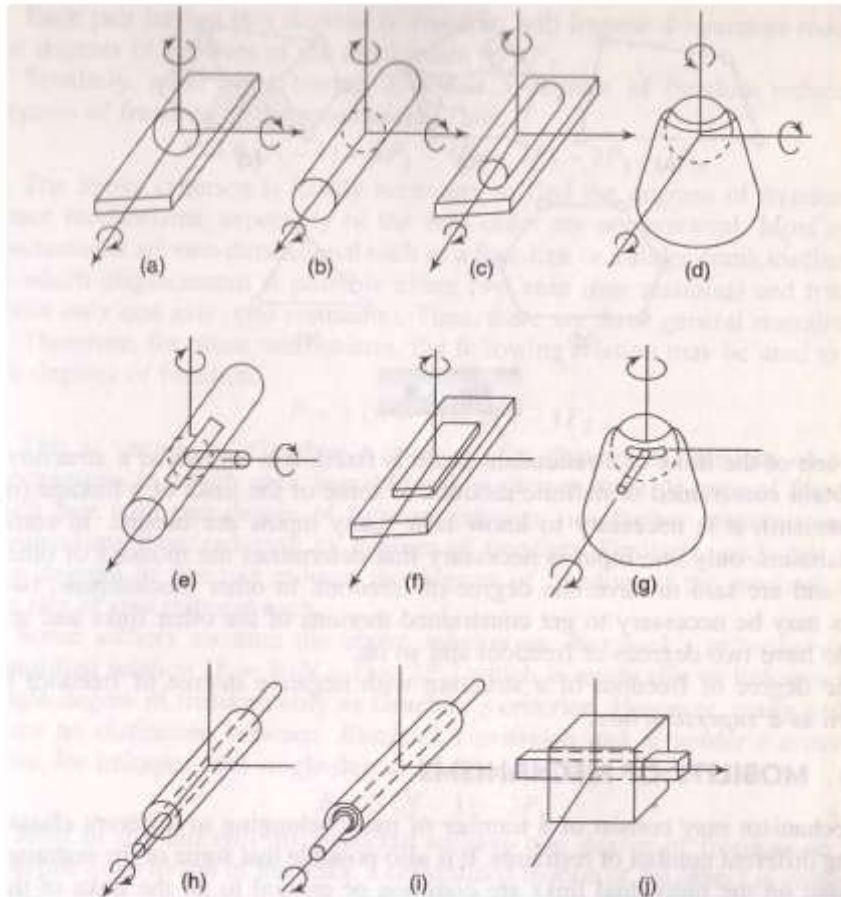

Figure – 4

Kinematic chain:

A kinematic chain is an assembly of links in which the relative motions of the links is possible and the motion of each relative to the other is definite.

Non – kinematic chain:

In case the motion of a link results in definite motions of other links, it is a non–kinematic chain.

A redundant chain: A redundant chain does not allow any motion of a link relative to the other.

Linkage:

A linkage is obtained if one of the links of a kinematic chain is fixed to the ground. If motion of any of the movable links results in definite motions of the others the linkage is known as a mechanism.

If one of the links of a redundant chain is fixed, it is known as a structure.

Mobility of mechanisms:

According to the number of general or common restraints a mechanism may be classified into different order.

A sixth order mechanism cannot exist since all the links become stationary and no movement is possible.

Degrees of freedom of a mechanism in space can be determined as follows.

Let  $N$  = total number of link in a mechanism  
 $F$  = degree of freedom.  
 $P_1$  = number of pairs having one degree of freedom.  
 $P_2$  = number of pairs having two degree of freedom

In mechanism one link is fixed

Number of degrees of freedom of  $(N-1)$  movable links =  $6(N-1)$  pair having one degree of freedom imposes 5 restraints on the mechanism reducing its degrees of freedom by  $5P_1$ .

Thus,  $F = 6(N-1) - 5P_1 - 4P_2 - 3P_3 - 2P_4 - 1P_5$

For plane mechanisms, the following relation may be used to find the degree of freedom.

$$\boxed{F = 3(N-1) - 2P_1 - 1P_2} \rightarrow \text{Gruebler's criterion.}$$

If the linkage has single degree of freedom then  $P_2 = 0$ , Hence

$$\boxed{F = 3(N-1) - 2P_1}$$

Most of the linkage are expected to have one degree of freedom.

$$\Rightarrow 1 = 3(N-1) - 2P_1$$

$$\Rightarrow 2P_1 = 3N - 4$$

As  $P_1$  and  $N$  are to be whole numbers, the relation can be satisfied only if as follows

$$N = 4, \quad P_1 = 4$$

$$N = 6, \quad P_1 = 7$$

$$N = 8, \quad P_1 = 10$$

Thus with the increase in the number of links, the number of excess turning pairs goes on increasing. To get required number of turning pairs from the required number of binary links not possible. Therefore the excess or the additional pairs or joints can be obtained only from the links having more than two joining points

## Equivalent Mechanisms:

It is possible to replace turning pairs of plane mechanisms by other type of pairs having one or two degrees of freedom, such as sliding pairs or cam pairs.

1. Sliding pair can be replaced as a turning pair with infinite length of radius.

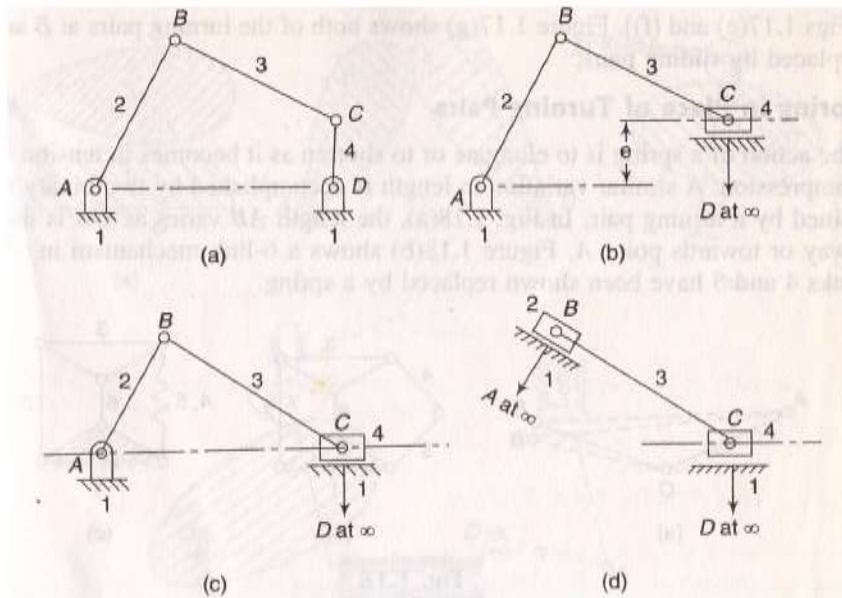

Figure - 5

2. Two sliding pair can be replaced as two turning pair if their sliding axes intersect.
3. The action of a spring is to elongate or to shorten as it becomes in tension or in compression. A similar variation in length is accomplished by two binary links joined by a turning pair.

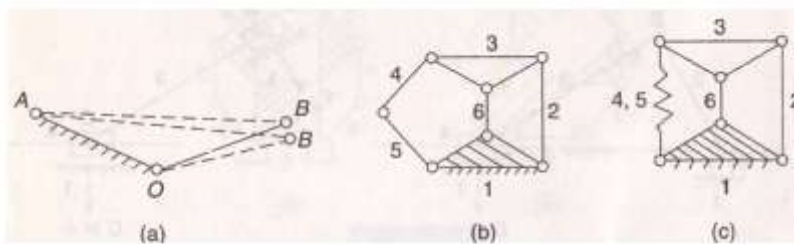

Figure - 6

4. A cam pair has two degrees of freedom



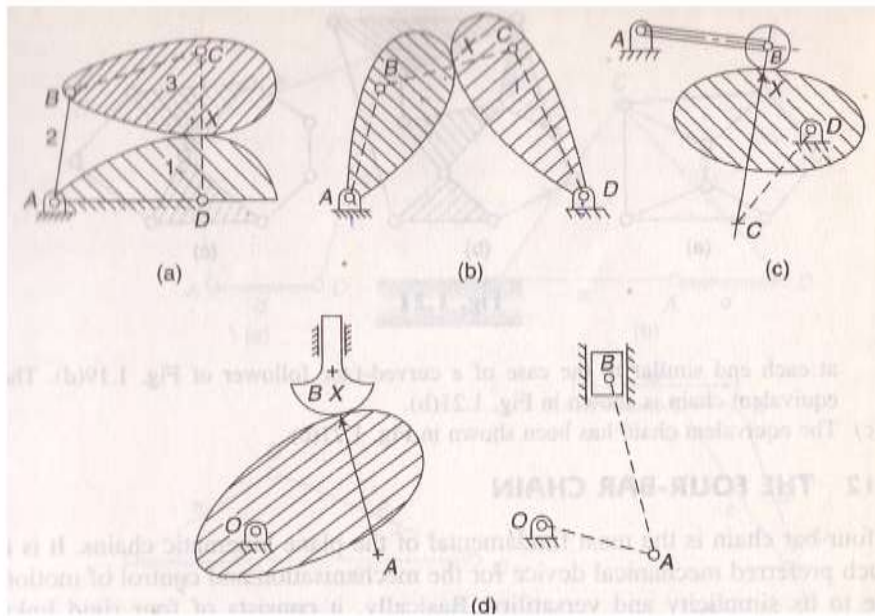

Figure - 7

$$F = 3(N - 1) - 2P_1 - 1P_2$$

A cam pair can be replaced by one binary link with two turning pairs at each end.

### The Four- bar chain:

A link that makes complete revolution is called the crank. The link opposite to the fixed link is called coupler and the fourth link is called lever or rocker if it oscillates or another crank if rotates. Condition for four-bar linkage is

$$d < a + b + c$$

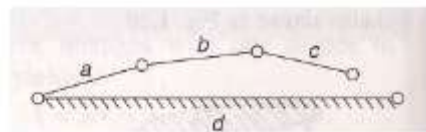

Figure - 8

Let  $a > d$ , then three extreme situations can be possible

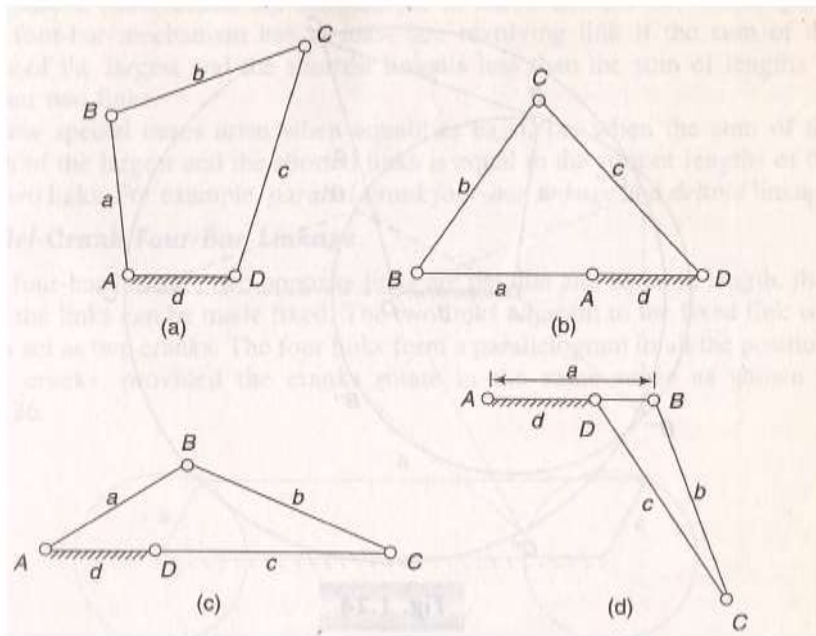

Figure - 9

(i)  $d + a < b + c$

(ii)  $d + c < a + b$

(iii)  $d + b < c + a$

Adding (i) and (ii)  $\Rightarrow 2d < 2b \quad \Rightarrow d < b$

Adding (ii) and (iii)  $\Rightarrow 2d < 2a \quad \Rightarrow d < a$

Adding (iii) and (i)  $\Rightarrow 2d < 2c \quad \Rightarrow d < c$

Thus the necessary conditions for the link 'a' to be a crank are that the shortest link is fixed and the sum of the shortest and the longest link is less than the sum of other two links.

If 'd' is fixed then a and c can rotate around d and also b; this is called drag – crank mechanism or rotary – rotary converter, or crank – crank or double crank mechanism.

B will rotate about a, if  $\angle ABC$  is greater than  $180^\circ$  in any case, and b will rotate about c if  $\angle DBC$  is more than  $180^\circ$  in any case.

Different mechanisms obtained by fixing different links of this kind of chain will be as follows (known as inversion).

1. If any of the adjacent links of link d i.e. a or c is fixed, d can have full revolution and link opposite to it oscillates. It is known as crank – rocker or crank- lever mechanism or rotary – oscillatory converter.
2. If the link opposite to the shortest link, i.e. link b is fixed and the shortest link d is made coupler, the other two links a and c would oscillate. The mechanism is called rocker – rocker or double – rocker or double – lever mechanism or oscillating – oscillating converter.

Shortest + longest < sum of other two → class-I four bar linkage.  
 Shortest + longest > sum of other two → class-II fourbar linkage.

All inversion s of class-II four bar linkage will give double rocker mechanism.

The above observations are summarized in the Grashof's law, which states that a four bar mechanism has at least one revolving link if the sum of the lengths of the largest and the shortest links is less than the sum of the lengths of the other two links.

Special cases when shortest+ longest = sum of other two.

Parallel – crank four bar: If  $b \parallel d$  (two opposite links are parallel) then all the inversions will be crank – crank mechanism. Ex : Parallel mechanism and anti parallel mechanism.

Deltoid linkage: If shortest link fixed → a double – crank mechanism is obtained, in which one revolution of the longer link causes two revolutions of the other shorter links.

If any of the longer links is fixed two crank – rocker mechanisms are obtained.

Mechanical advantage:

The mechanical advantage of a mechanism is the ratio of the output force or torque to the input force or torque at an instant. Let friction and inertia forces are neglected.

$$M.A. = \frac{\text{out put force/torque}}{\text{input force/torque}}$$

Power input = power output (If loss is zero)

$$T_2\omega_2 = T_4\omega_4$$

$$\Rightarrow M.A. = \frac{T_4}{T_2} = \frac{\omega_2}{\omega_4} = \text{ratiprocal of velocity ratio}$$

In case crank rocker mechanism  $\omega_4$  of the output link is zero at extreme positions, i.e. when input link is in line with coupler link or  $\gamma = 0^\circ$  or  $180^\circ$ , the mechanical advantage is infinity. Only a small input torque can overcome a large output torque load. The extreme positions of the linkage are known as toggle positions.

Transmission angle:

The angle  $\mu$  between the out put link and the coupler is known as transmission angle. The torque transmitted to the output link is maximum when the transmission angle  $\mu$  is  $90^0$ . If  $\mu = 0^0, 180^0$ , the mechanism would lock or jam.

If  $\mu$  deviates significantly from  $90^0$  the torque on output link decreases. Hence  $\mu$  is usually kept more than  $45^0$ .

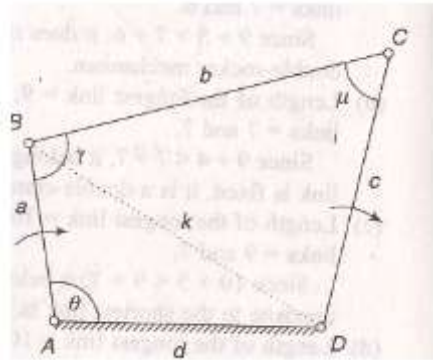

Figure - 10

Applying cosine law to triangles ABD and BCD,

$$a^2 + d^2 - 2ad \cos\theta = k^2$$

$$b^2 + c^2 - 2bc \cos\mu = k^2$$

$$\Rightarrow a^2 + d^2 - 2ad \cos \theta = b^2 + c^2 - 2bc \cos \mu$$

$$\Rightarrow a^2 + d^2 - b^2 - c^2 - 2ad \cos \theta + 2bc \cos \mu = 0$$

The maximum or minimum values of transmission angle can be found out by putting  $d\mu / d\theta$  equal to zero. Differentiating with  $\theta$

$$\Rightarrow ad \sin \theta - bc \sin \mu \times \frac{d\mu}{d\theta} = 0$$

$$\Rightarrow \frac{d\mu}{d\theta} = \frac{ad \sin \theta}{bc \sin \mu}$$

$\frac{d\mu}{d\theta}$  is zero when  $\theta = 0^0$  or  $180^0$ .

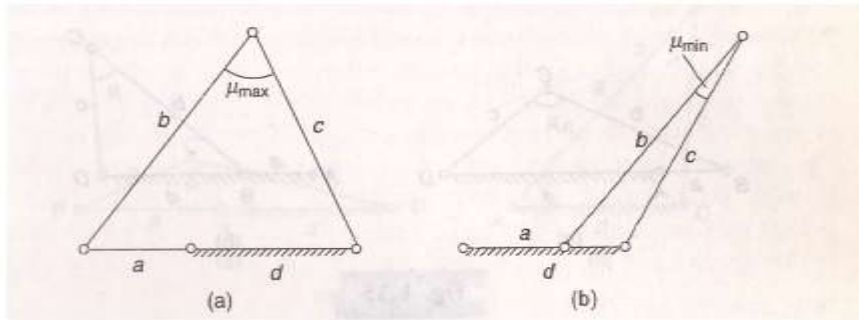

Figure - 11

The slider crank chain:

When one of the turning pairs of four bar chain is replaced by a sliding pair, it is called as single – slider crank chain or slider crank chain.

When two of turning pairs of four bar chain is replaced by two sliding pair, it is called as double slider – crank chain.

If the sliding path line passes parallel with the fixed pivot point with some offset then it is called offset slider crank chain.

Inversions of single slider crank chain:

Different mechanisms obtained by fixing different links of a kinematic chain are known as its inversions.

1<sup>st</sup> Inversion: The inversion is obtained when link 1 is fixed and links 2 and 4 are made the crank and the slider respectively.

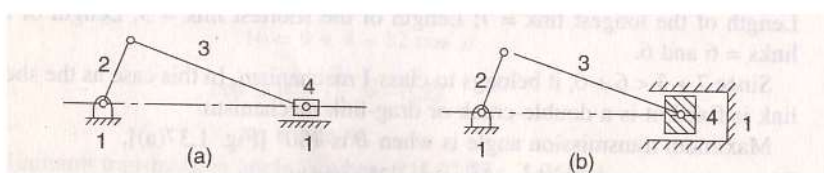

Figure - 12

- Applications:
1. Reciprocating engine.
  2. Reciprocating compressor.

2<sup>nd</sup> Inversion: Fixing of link 2 of a slider – crank chain results in the second inversion. When its link 2 is fixed instead of link 1, link 3 along with the slider at its end B becomes a crank. This makes link 1 to rotate about o along with the slider which also reciprocates on it.

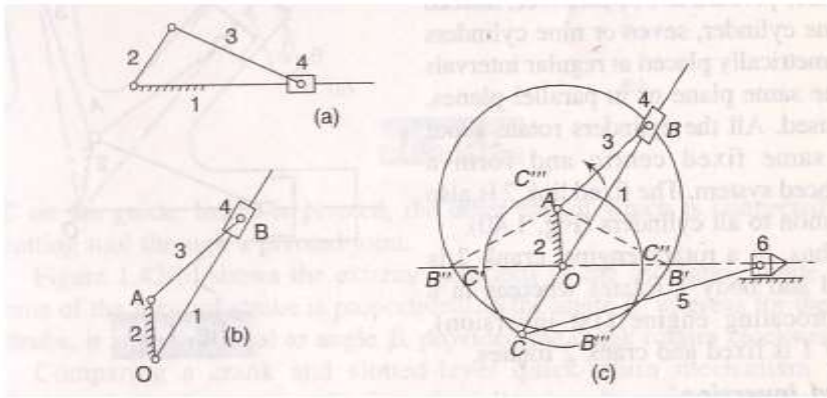

Figure - 13

- Applications:
1. White worth quick- return mechanism
  2. Rotary engine.

3<sup>rd</sup> Inversion: By fixing link 3 of the slider crank mechanism, third inversion is obtained. Here link 2 again acts as a crank and link 4 oscillates.

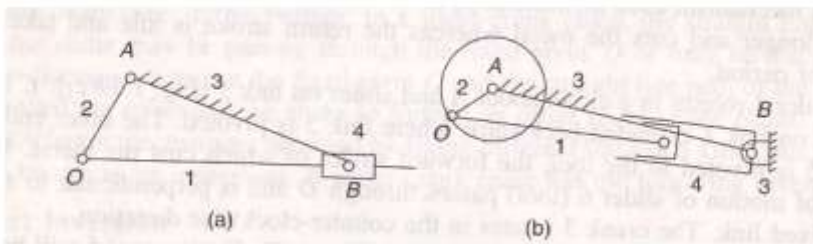

Figure - 14

- Applications:
1. Oscillating cylinder engine

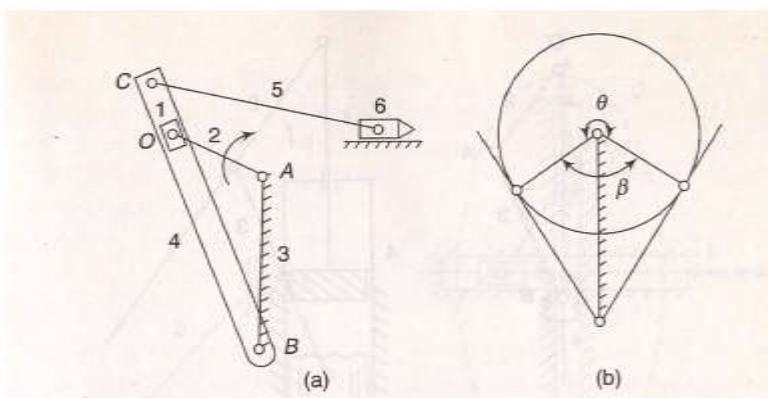

Figure - 15

2. Crank and slotted – lever mechanism.

4<sup>th</sup> Inversion: If link 4 of the slider – crank mechanism is fixed the fourth inversion is obtained. Link 3 can oscillate about the fixed pivot B on link 4. This

makes end A of link 2 to oscillate about B and end O to reciprocate along the axis of the fixed link 4.

Applications: Hand pump.

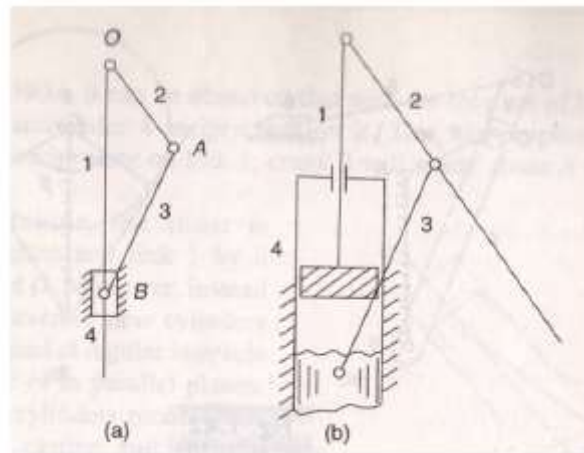

Figure - 16

Inversion of double slider – crank chain:

First inversion: The inversion is obtained when link 1 is fixed and the two adjacent pairs 23 and 34 are turning pairs and the other two pairs 12 and 41 sliding pairs.

Application: Elliptical trammel.

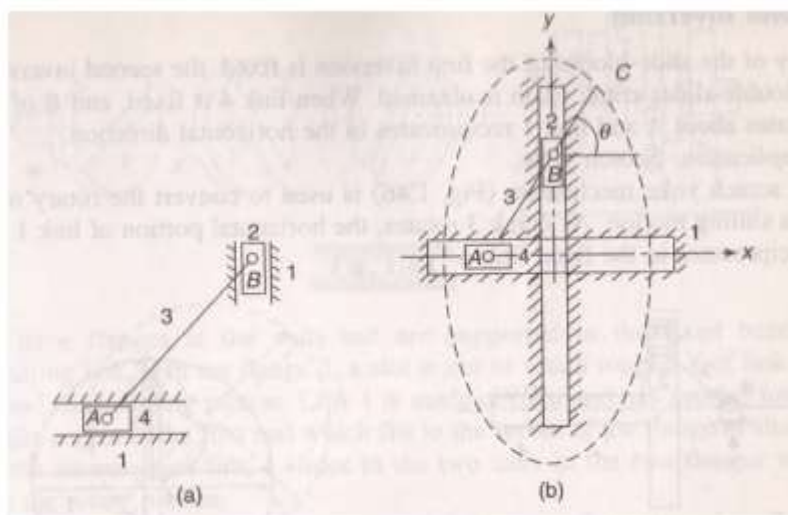

Figure - 17

Second Inversion: If any of the slide – blocks of the first inversion is fixed, the second inversion of the double – slider – crank chain is obtained. When link 4 is

fixed, end B of crank 3 rotates about A and link 1 reciprocates in the horizontal direction.

Application : Scotch yoke.

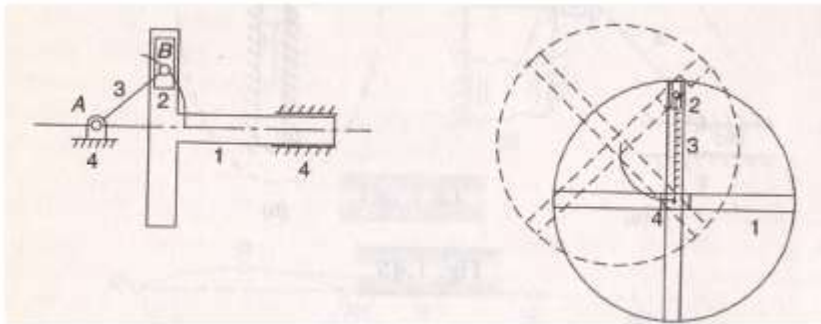

Figure - 18

Third Inversion: This inversion is obtained when link 3 of the first inversion is fixed and link 1 is free to move.

Application: Oldham's coupling.

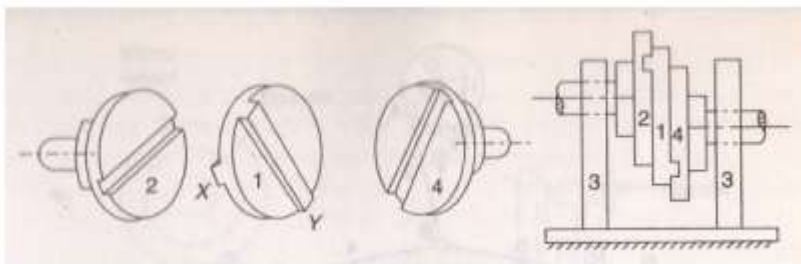

Figure - 19

Oldham coupling is used to connect two parallel shafts when the distance between their axes is small.

### Velocity Analysis

Analysis of mechanisms is the study of motions and forces concerning their different parts.

The study of velocity analysis involves the linear velocities of various points on different links of a mechanism as well as the angular velocities of the links.

When a machine or a mechanism is represented by a skeleton or a line diagram, then it is commonly known as a configuration diagram. Velocity analysis can be done two methods. 1. Analytical and 2. Graphically. Analytical method more convenient by computers. Graphical method is more direct and accurate to an



acceptable degree. This graphical approach is done by two methods, i.e. (a) relative velocity method and (b) Instantaneous method.

Vector and vector addition/substraction:

$$\vec{V}_{ba} = \vec{a} \rightarrow \vec{b}$$

Velocity of a body B relative to A.

$$\vec{V}_{bo} = \vec{V}_{ba} + \vec{V}_{ao}, \Rightarrow ob = oa + ab;$$

$$\Rightarrow \vec{V}_{ba} = \vec{V}_{bo} - \vec{V}_{ao}$$

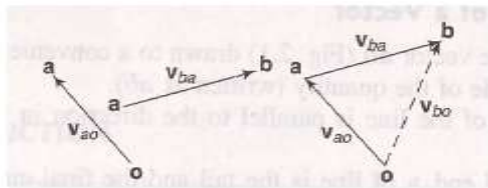

Figure – 20

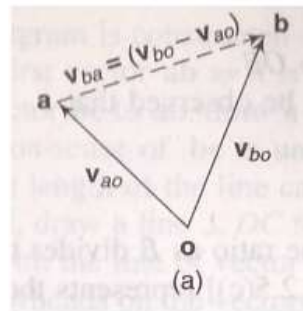

Figure - 21

Motion of a link:

Let a rigid link OA, of length r, rotate about a fixed point o with a uniform angular velocity  $\omega$  rad/s in the counter – clockwise direction. OA turns through a small angle  $\delta\theta$  in a small interval of time  $\delta t$  . Then A will travel along the arc as shown in figure.

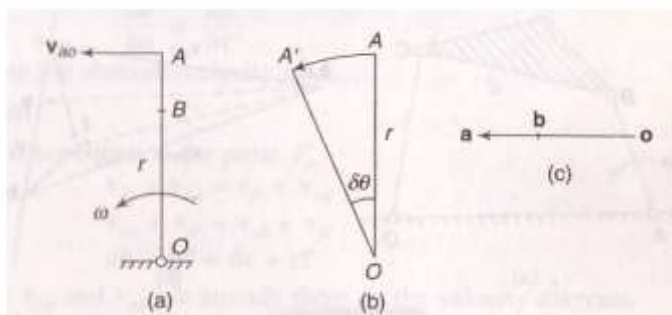

Figure - 22

$$\text{Velocity of A relative to O} = \frac{\text{Arc } AA'}{\delta t} \text{ or } \vec{V}_{ao} = \frac{r\delta\theta}{\delta t} = \omega r$$

The direction of  $\vec{V}_{ao}$  is along the displacement of A. Also, as  $\delta t$  approaches zero ( $\delta t \rightarrow 0$ ),  $AA'$  will be perpendicular to  $OA$ . Thus velocity of A is  $\omega r$  and is perpendicular to  $OA$ . This can be represented by a vector  $oa$ .

Consider a point B on the link OA.

Velocity of B =  $\omega \cdot OB$  (perpendicular to  $OB$ ).

If  $ob$  represents the velocity of B, it can be observed that

$\frac{ob}{oa} = \frac{\omega OB}{\omega OA} = \frac{OB}{OA}$  i.e.  $b$  divides the velocity vector in the same ratio as B divides the link.

#### Four – link mechanism:

In the four – link mechanism ABCD, AD is fixed, so  $a$  &  $d$  will be one fixed point in velocity diagram. It is required to find out the absolute velocity of C. Writing the velocity vector equation,

Vel. of C rel. to A = Vel. of C rel. to B + vel. of B rel. to A  $\perp$  = Vel. of C rel to D

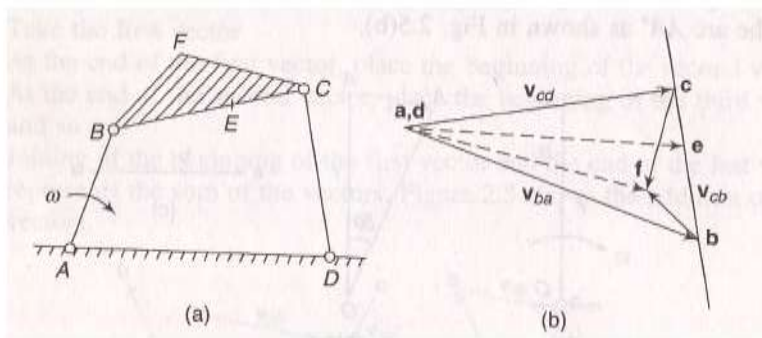

Figure - 23

$$\vec{V}_{ca} = \vec{V}_{cb} + \vec{V}_{ba} = \vec{V}_{cd}$$

$$\Rightarrow dc = bc + ab$$

$$\Rightarrow ac = bc + bc$$

$$\vec{V}_{ba} \text{ or } ab = \omega \cdot AB; \perp \text{ to } AB$$

$$\vec{V}_{cb} \text{ or } bc \text{ is unknown in magnitude; } \perp \text{ to } BC.$$

$\vec{V}_{cd}$  or dc is unknown in magnitude;  $\perp$  to DC.

Intermediate point:

For point E on the link BC,  $\frac{be}{bc} = \frac{BE}{BC}$ ,  $ae$  represents the absolute velocity of E.

Offset point:

Write the vector equation for point F,

$$\vec{V}_{fb} + \vec{V}_{ba} = \vec{V}_{fc} + \vec{V}_{cd}$$

$$\vec{V}_{ba} + \vec{V}_{fb} = \vec{V}_{cd} + \vec{V}_{fc}$$

$$ab + bf = cf$$

The vector  $\vec{V}_{ba}$  and  $\vec{V}_{cd}$  are there on the velocity diagram.

$\vec{V}_{fb}$  is  $\perp$  BF; draw a line  $\perp$  BF through b.

$\vec{V}_{fc}$  is  $\perp$  CF; draw a line  $\perp$  CF through c.

The intersection of the two lines locates the point f. af indicates the velocity of F relative to A or absolute velocity of F.

Velocity Images

Triangle bfc is similar to triangle BFC in which all the three sides bc, cf, fb are perpendicular to BC, CF, and FB respectively. The triangles such as bfc are known as velocity images.

1. Velocity image of a link is a scaled reproduction of the shape of the link in a velocity diagram, rotated bodily through  $90^\circ$  in the direction of angular velocity.
2. Order of letter is same as in configuration diagram.
3. Ratios of different images of different links are different.

Angular velocity of links:

1. Angular velocity of BC :

(a) Velocity of C relative to B,  $\vec{V}_{cb}$  (upward).

Thus C moves in the counter clockwise direction about B.

$$\vec{V}_{cb} = \omega_{cb} \times BC$$

$$\omega_{cb} = \frac{\vec{V}_{cb}}{CB}$$

- (b) Velocity of B relative to C,  $\vec{V}_{bc}$  (downward)  
 i.e. B moves in the counter – clockwise direction about C.

$$\omega_{bc} = \frac{\vec{V}_{bc}}{BC}$$

2. Angular velocity of CD:

Velocity of C relative to D,  $\vec{V}_{cd}$  (clockwise)

$$\omega_{cd} = \frac{\vec{V}_{cd}}{CD}$$

Velocity of rubbing:

The rubbing velocity of the two surfaces will depend upon the angular velocity of a link relative to the other.

Pin at A : Let  $r_a$  = radius of the pin at A.  
 Then the velocity of rubbing =  $r_a \cdot \omega_{ba}$

Pin at D : Let  $r_d$  = radius of the pin at D.

Velocity of rubbing =  $r_d \cdot \omega_{cd}$

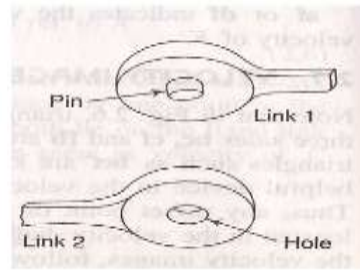

Figure - 24

Pin at B:  $\omega_{ba} = \omega_{ab} = \omega$ (clockwise),  $\omega_{bc} = \omega_{cb} = \frac{\vec{V}_{cb}}{BC}$  ( counter clockwise). Since the directions of the two angular velocities of links AB and BC are in the opposite directions the angular velocity of one link relative to other is sum of the velocities.

Let  $r_b$  = radius of the pin at B , Velocity of rubbing =  $r_b(\omega_{ab} + \omega_{bc})$

Pin at C:  $\omega_{bc} = \omega_{cb}$  (counter clockwise)

$\omega_{dc} = \omega_{cd}$  (clockwise)

$r_c$  = radius of pin at C.

Velocity of rubbing =  $r_c (\omega_{bc} + \omega_{dc})$

Slider – crank Mechanism:

Figure shows a slider – crank mechanism in which OA is the crank moving with uniform angular velocity  $\omega$  rad/s in the clockwise direction. At point B, a slider moves

on the fixed guide G. AB is the coupler joining A and Bm. It is required to find out the velocity of slider at B.

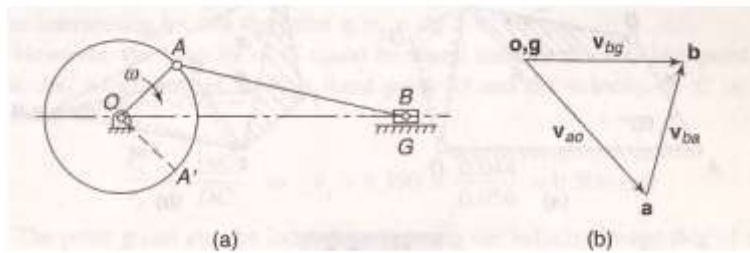

Figure - 25

Velocity of B relative to O = Velocity of B relative to A + velocity of A relative to O

$$\Rightarrow \vec{V}_{bo} = \vec{V}_{ba} + \vec{V}_{ao}$$

Take the vector  $\vec{V}_{ao}$  which is completely known.

$$\vec{V}_{ao} = \omega \cdot OA; \perp \text{ to } OA$$

$\vec{V}_{ba} \perp AB$ , draw a line parallel to the motion of B.

$\vec{V}_{bo} \parallel OG$ . Through g, draw a line parallel to the motion of B.

The intersection of two lines locates 'b'.  $\vec{V}_{bo}$  the slider velocity with respect to G.

The coupler AB has angular velocity in counter clockwise direction  $= \frac{\vec{V}_{ba}}{AB}$

Crank and slotted lever mechanism:

A crank and slotted – lever mechanism, in which OP is the crank rotating at an angular speed  $\omega$  rad/s in the clockwise direction about center O. A slider P is pivoted which moves on an oscillating link ASR. P and Q are coincident points. As the crank rotates there is relative movement of the points P and Q along AR.

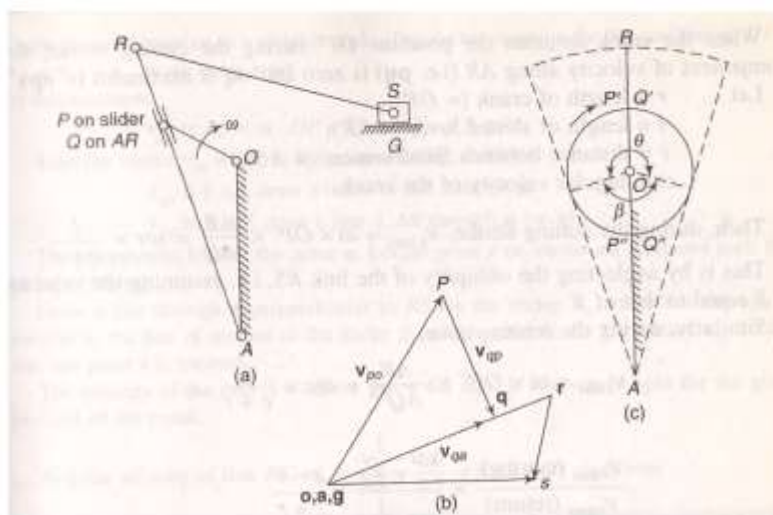

Figure - 26

Writing the velocity vector equation for the mechanism OPA.

Velocity of Q relative to O = velocity of Q relative to P + velocity of P relative to O.

$$\Rightarrow \vec{V}_{qo} = \vec{V}_{qp} + \vec{V}_{po}$$

$$\Rightarrow \vec{V}_{qa} = \vec{V}_{po} + \vec{V}_{qp}$$

$$\vec{V}_{po} = \omega \cdot OP, \perp \text{ to } OP$$

$\vec{V}_{qp}$  is unknown in magnitude;  $\parallel$  to AR.

$\vec{V}_{qa}$  is unknown in magnitude;  $\perp$  to AR.

Construction of velocity diagram:

Draw  $\vec{V}_{po}, \vec{V}_{qp} \parallel AR$  through P

$\vec{V}_{qa} \perp AR$ , draw a line  $\perp AR$  through a.

The intersection point is 'q'.  $\vec{V}_{qp}$  shows the velocity of sliding of the block on link AR. The point r will lie on vector 'aq' produced such that  $\frac{ar}{aq} = \frac{AR}{AQ}$ . To find

the velocity of ram S, the velocity vector equation is

$$\vec{V}_{so} = \vec{V}_{sr} + \vec{V}_{ro},$$

$$\Rightarrow \vec{V}_{sg} = \vec{V}_{ro} + \vec{V}_{sr}$$

$\vec{V}_{ro}$  is already in the diagram. Draw a line through r perpendicular to RS for vector  $\vec{V}_{sr}$  and a line of motion of the slider S on the guide G, for the vector  $\vec{V}_{sg}$ . So S is located.

$\vec{V}_{sg}$  = velocity of the slider.

$$\omega_{rs} = \frac{\vec{V}_{rs}}{RS} \text{ (clockwise).}$$

$$\frac{V_s \text{ max( cutting )}}{V_s \text{ max( returning )}} = \frac{c - r}{c + r},$$

Where  $c$  = distance between fixed center,

and  $r$  = crank length.

Instantaneous center:

The body can be imagined to rotate about some point on the line perpendicular to the velocity vector passing through that point.

The intersection point of two different lines is called instantaneous center of rotation (I – center). An I – center is a center of rotation of a moving body relative to another body. It is named as  $I_{pq}$  and it will be in ascending order of the alphabets or digits.

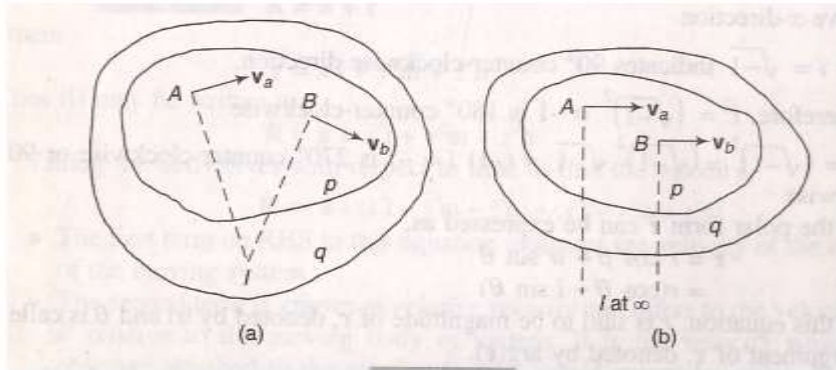

Figure - 27

Number of I-centers in a mechanism =  $N = \frac{n(n-1)}{2}$  where  $n$  = number of links.

Kennedy's theorem:

If three plane bodies have relative motion among themselves, their I-center must lie on a straight line.

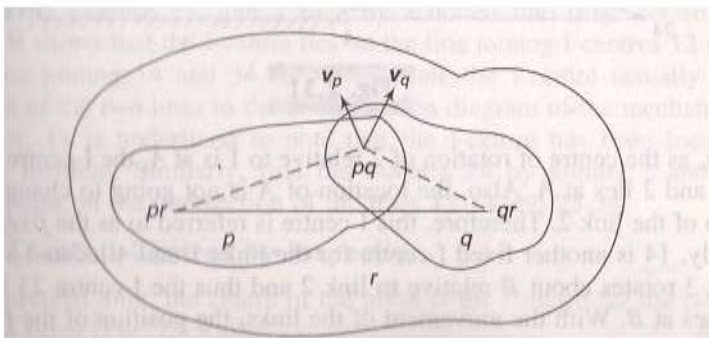

Figure - 28

Locating I-centers:

A four-link mechanism ABCD has 4 links named 1,2,3,4. The number of I-centers is

$$N = \frac{n(n-1)}{2} = \frac{4(4-1)}{2} = 6$$

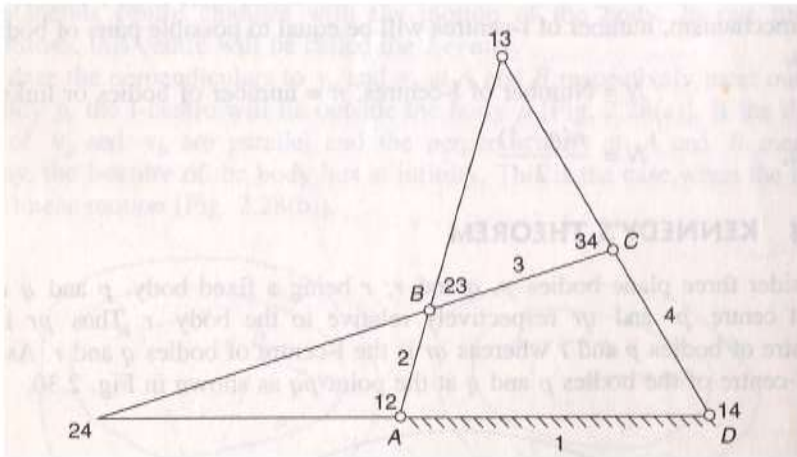

Figure - 29

I-center 12 and 14 are fixed I-centers.

I-center 23 and 34 are permanent but not fixed I-centers.

I-center 13 and 24 which are neither fixed nor permanent can be located easily by applying Kennedy's theorem as explained below.

I-center 13:

As the three links 1, 2, 3 have relative motions among themselves, their I-centers lie on a straight line. Thus I-center 13 lies on the line joining 12 and 23.

Similarly I-center 13 lies on the line joining 14 and 34. The intersection of the two lines locates the I-center 13.

I-center 24: Considering two sets of links 2, 1, 4 and 2, 3, 4, the I-center would lie on the lines 12-14 and 23-34. The intersection locates the I-center 24.

Rules to Locate I-centers by inspections:

1. In a pivoted joint, the center of the pivot is the I-center for the two links.
2. In a sliding motion, the I-center lies at infinity in a direction perpendicular to the path of motion of the slider.
3. In a pure rolling contact of the two links, the I-center lies at the point of contact at the given instant.

### Acceleration Analysis



The rate of change of velocity with respect to time is known as acceleration and acts in the direction of the change in velocity. A change in the velocity requires any of the following conditions to be fulfilled.

- (i) A change in the magnitude only
- (ii) A change in direction only
- (iii) A change in both magnitude and direction.

Acceleration: Let a link OA, of length  $r$ , rotate in a circular path in the clockwise direction as shown in figure. It has instantaneous angular velocity  $\omega$  and an angular acceleration  $\alpha$  in the same direction, i.e the angular velocity increases in the clockwise direction. Tangential velocity of A,  $v_a = \omega r$ . In short interval of time  $\delta t$ , let OA assume the new position OA' by rotating through a small angle  $\delta\theta$ .

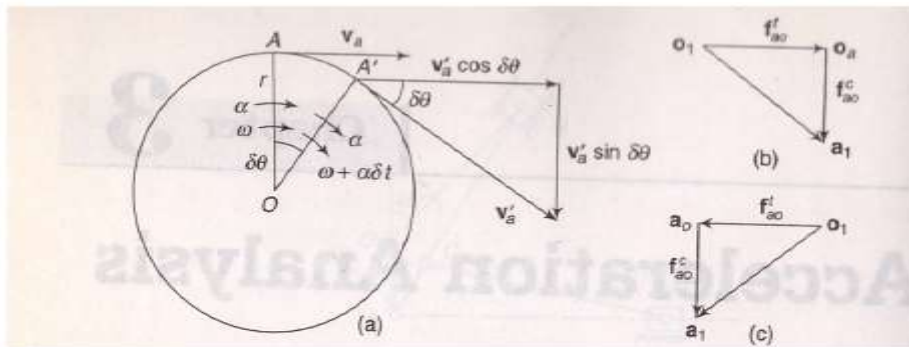

Figure - 30

Angular velocity of OA',  $\omega_a' = \omega + \alpha \cdot \delta t$ .

Tangential velocity of A',  $V_a' = (\omega + \alpha \cdot \delta t)r$ .

The tangential velocity of A' may be considered to have two components; one perpendicular to OA and the other parallel to OA.

Change of velocity perpendicular to OA:

Velocity of A  $\perp$  to OA =  $V_a$

Velocity of A'  $\perp$  to OA =  $V_a' \cos \delta\theta$

Change of velocity =  $V_a' \cos \delta\theta - V_a$

Acceleration of A  $\perp$  to OA =  $\frac{(\omega + \alpha \cdot \delta t)r \cos \delta\theta - \omega r}{\delta t}$

In the limit, as  $\delta t \rightarrow 0$ ,  $\cos \delta\theta \rightarrow 1$

$$\therefore \text{Acceleration of A } \perp \text{ to OA} = \frac{\omega r + \alpha r \delta t - \omega r}{\delta t} = \alpha r = \frac{d\omega}{dt} r = \frac{d(\omega r)}{dt} = \frac{dv}{dt}$$

This represents the rate of change of velocity in the tangential direction of the motion of A relative to O and thus is known as the tangential acceleration.

Change of velocity parallel to OA:

Velocity of A parallel to OA = 0

Velocity of A' parallel to OA =  $V_a' \sin \delta\theta$

Change of Velocity =  $V_a' \sin \delta\theta - 0$

$$\text{Acceleration of A parallel to OA} = \omega r \frac{d\theta}{dt} = \omega r \cdot \omega = \omega^2 r = \frac{V^2}{r}$$

This represents the rate of change of velocity along OA, the direction being from A towards O or towards the center of rotation. It is known as centripetal acceleration and denoted by  $f_{ao}^c$ .

Four – link mechanism:

Let  $\alpha$  = angular acceleration of AB at this instant assumed positive, i.e. the speed increases in the clockwise direction.

Acceleration of C relative to A = Acceleration of C relative to B + Acceleration of B relative to A.

$$\vec{f}_{ca} = \vec{f}_{cb} + \vec{f}_{ba}$$

$$\vec{f}_{cd} = \vec{f}_{ba} + \vec{f}_{cb}$$

Each of these accelerations may have a centripetal and a tangential component. Thus the equation can be expanded as below,

$$\vec{f}_{cd}^c + \vec{f}_{cd}^t = \vec{f}_{ba}^c + \vec{f}_{ba}^t + \vec{f}_{cb}^c + \vec{f}_{cb}^t$$

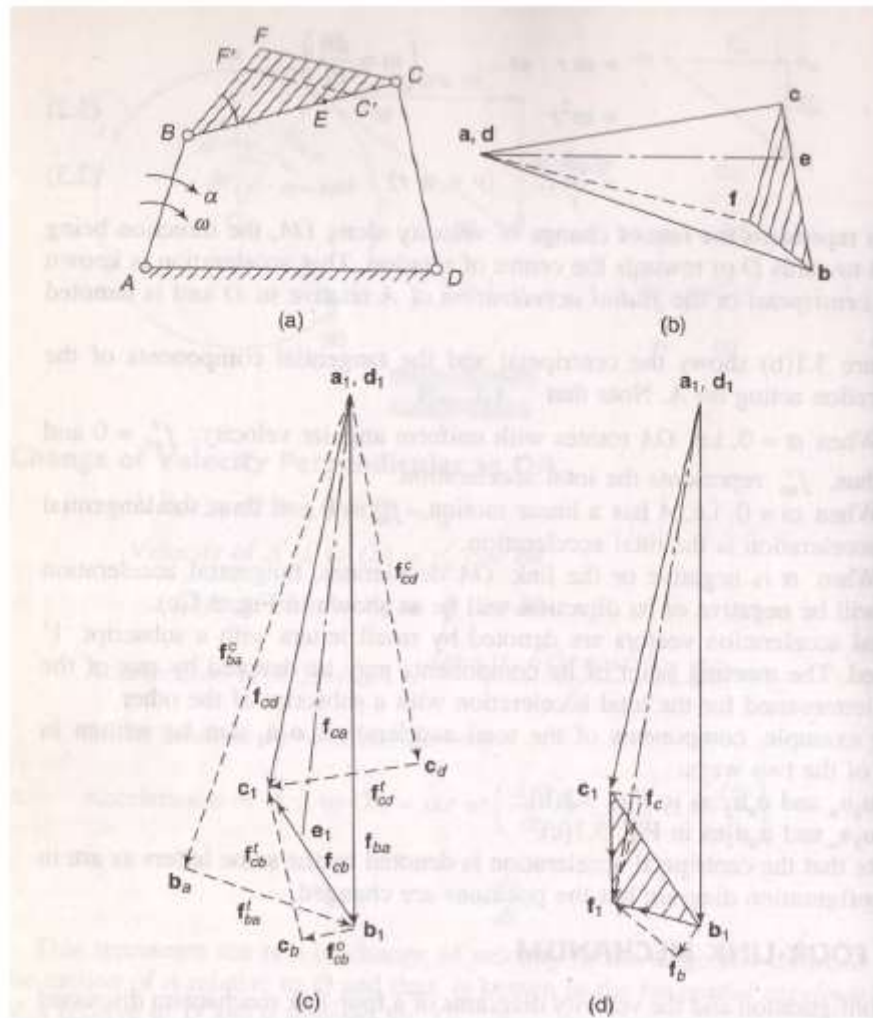

Figure - 31

Set the following table:

S.N.	Vector	Magnitude	Direction	Sense
1.	$\vec{f}_{ba}^c$ or $\vec{a}_1b_a$	$\frac{(ab)^2}{AB}$	$\square AB$	$\rightarrow A$
2.	$\vec{f}_{ba}^t$ or $\vec{b}_ab_a$	$\alpha \times AB$	$\perp$ to $\vec{AB}$ or $\vec{a}_1b_a$	$\rightarrow b$
3.	$\vec{f}_{cb}^c$ or $\vec{b}_1c_b$	$\frac{(bc)^2}{BC}$	$\square BC$	$\rightarrow B$
4.	$\vec{f}_{cb}^t$ or $\vec{c}_bc_1$	—	$\perp$ to $\vec{BC}$ or $\vec{b}_1c_b$	—
5.	$\vec{f}_{cd}^c$ or $\vec{d}_1c_d$	$\frac{(dc)^2}{DC}$	$\square$ to $\vec{DC}$	$\rightarrow D$

6.	$\vec{f}_{cd}^t$ or $\vec{c}_d c_1$	—	$\perp$ to $\vec{DC}$ or $\vec{d}_1 c_d$	—
----	-------------------------------------	---	--	---

Construction of the acceleration diagram:

- Select the pole point  $a_1$  or  $d_1$ .
- Take the first vector from the above table, i.e. take  $a_1 b_a$  to a convenient scale in the proper direction and sense.
- Add the second vector to the first and then the third vector to the second.
- For the addition of the fourth vector, draw a line perpendicular to BC through the head  $c_b$  of the third vector. The magnitude of the fourth vector is unknown and  $c_1$  can lie on either side of  $c_b$ .
- Take the fifth vector from  $d_1$ .
- For the addition of the sixth vector to the fifth, draw a line perpendicular to DC through head  $c_d$  of the fifth vector. The intersection of this line with the line drawn in step (d) locates the point  $c_1$ .

Total acceleration of B =  $a_1 b_1$

Total acceleration of C relative to B =  $b_1 c_1$

Total acceleration of C =  $d_1 c_1$

Angular acceleration of links: It can be observed that the tangential component of acceleration occurs due to the angular acceleration of a link.

Tangential acceleration of B relative to A is

$$\vec{f}_{ba}^t = \alpha \cdot AB$$

$$\Rightarrow \alpha_{ba} = \frac{f_{ba}^t}{AB}$$

Similarly  $\alpha_{cb} = \frac{f_{cb}^t}{CB}$

$$\alpha_{cd} = \frac{f_{cd}^t}{CD}$$

Acceleration of intermediate and offset points:

The acceleration of intermediate points on the links can be obtained by dividing the acceleration vectors in the same ratio as the points divide the links. For point

E on the link BC is  $\frac{BE}{BC} = \frac{b_1e_1}{b_1c_1}$

Offset points: The acceleration of an offset point on a link, such as F on BC can be determined by applying any of the following method.

(1) Writing the vector equation

$$\vec{f}_{fb} + \vec{f}_{ba} = \vec{f}_{fc} + \vec{f}_{cd}$$

Or  $\vec{f}_{ba} + \vec{f}_{fb} = \vec{f}_{cd} + \vec{f}_{fc}$

Or  $\vec{f}_{ba} + \vec{f}_{fb}^c + \vec{f}_{fb}^t = \vec{f}_{cd} + \vec{f}_{fc}^c + \vec{f}_{fc}^t$

Or  $a_1\vec{b}_1 + b_1\vec{f}_b + f_b\vec{f}_1 = d_1\vec{c}_1 + f_1\vec{f}_c + f_c\vec{f}_1$

The equation can be easily solved graphically as shown.  $a_1\vec{f}_1$  represents the acceleration of F relative to A or D.

(2) Writing the vector equation,

$$\vec{f}_{fa} = \vec{f}_{fb} + \vec{f}_{ba}$$

$$= \vec{f}_{ba} + \vec{f}_{fb}$$

$$= \vec{f}_{ba} + \vec{f}_{fb}^c + \vec{f}_{fb}^t$$

Or  $a_1\vec{f}_1 = a_1\vec{b}_1 + b_1\vec{f}_b + f_b\vec{f}_1$

$\vec{f}_{ba}$  already exists on the acceleration diagram.

S.N.	Vector	Magnitude	Direction	Sense
1.	$\vec{f}_{fb}^c$	$\vec{f}_{fb}^c = \frac{(bf)^2}{BF}$	$\perp$ to BF	$\rightarrow$ B

2.	$\vec{f}_{fb}^t$	$\vec{f}_{fb}^t = \alpha_{fb} \times FB$ $= \alpha_{cb} \times FB$ $= \frac{f_{cb}^t}{CB} \times FB$	$\perp$ to FB	$b \rightarrow f$
----	------------------	--	---------------	-------------------

$\alpha_{fb} = \alpha_{cb}$ , because angular acceleration of all the points on the link BCF about the point B is the same (counter – clockwise).

In this way  $\vec{f}_{fa}$  can be found.

Acceleration of slider–crank mechanism :

Writing the acceleration equation,

Acc. of B rel. to O = Acc. Of B rel. to A + Acc. Of A rel. to O

$$\vec{f}_{bo} = \vec{f}_{ba} + \vec{f}_{ao}$$

$$\vec{f}_{bg} = \vec{f}_{ao} + \vec{f}_{ba} = \vec{f}_{ao} + \vec{f}_{ba}^c + \vec{f}_{ba}^t$$

$$g_1 b_1 = o_1 a_1 + a_1 b_a + b_a b_1$$

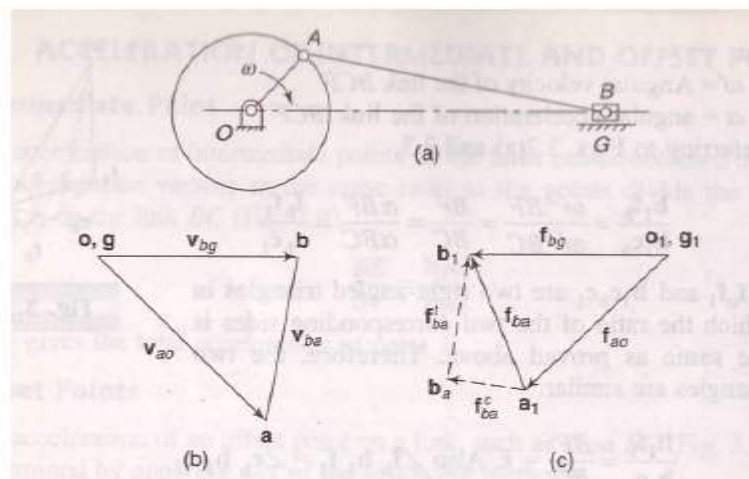

Figure - 32

The crank OA rotates at a uniform velocity, therefore, the acceleration of A relative to O has only the centripetal component. Similarly, the slider moves in a linear direction and thus has no centripetal component.

Setting the vector table:

S.N.	Vector	Magnitude	Direction	Sense
1.	$\vec{f}_{ao}$ or $o_1\vec{a}_1$	$\frac{(oa)^2}{OA}$	$\square OA$	$\rightarrow O$
2.	$\vec{f}_{ba}^c$ or $a_1\vec{b}_a$	$\frac{(ab)^2}{AB}$	$\square AB$	$\rightarrow A$
3.	$\vec{f}_{ba}^t$ or $b_a\vec{b}_1$	—	$\perp AB$	—
4.	$\vec{f}_{bg}$ or $g_1\vec{b}_1$	—	$\square$ to line of motion of B	—

Construct the acceleration diagram as follows:

1. Take the first vector  $\vec{f}_{ao}$ .
2. Add the second vector to the 1<sup>st</sup>.
3. For the third vector, draw as line  $\perp$  to AB through the head  $b_a$  of the second vector.
4. For the fourth vector, draw a line through  $g_1$  parallel to the line of motion of the slider.

This completes the velocity diagram.

Acceleration of the slider B =  $g_1b_1$

Total acceleration of B relative to A =  $a_1b_1$ .

Note that if the direction of the acceleration of slider is opposite to that of the velocity, then the slider decelerates.

### Coriolis Acceleration Component:

Coriolis component exists only if there are two coincident points which have linear relative velocity of sliding and angular motion about fixed finite centres of rotation.

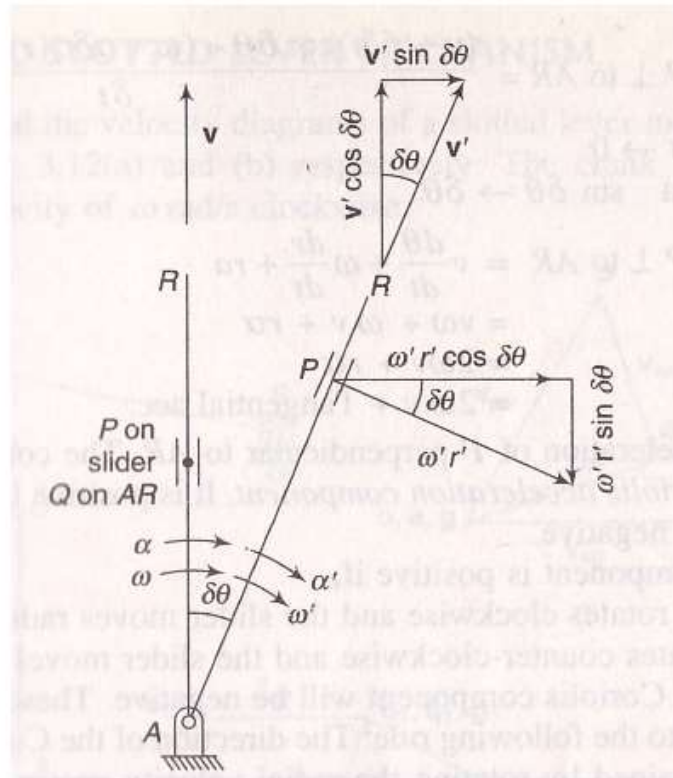

Figure - 33

Let a link AR rotate about a fixed point A on it. P is a point on a slider on the link. At any given instant, Let

- $\omega$  = Angular velocity of the link
- $\alpha$  = Angular acceleration of the link
- $v$  = Linear velocity of the slider on the link
- $f$  = Linear acceleration of the slider on the link
- $r$  = Radial distance of point P on the slider

In a short interval of time  $\delta t$  let  $\delta\theta$  be the angular displacement of the link and  $\delta r$  the displacement of the slider in the outward direction.

After the short interval of time  $\delta t$ , let

- $\omega' = \omega + \alpha \cdot \delta t$  = angular velocity of the link.
- $v' = v + f \cdot \delta t$  = Linear velocity of the slider on the link.
- $r' = r + \delta r$  = Radial distance of the slider.

Acceleration of P Parallel to AR:

Initial velocity of p along AR =  $v = v_{pq}$

Final velocity of p along AR =  $v' \cos \delta\theta - \omega' r' \sin \delta\theta$

Change of velocity along AR =  $(v' \cos \delta\theta - \omega' r' \sin \delta\theta) - v$

$$\text{Acceleration of P along AR} = \frac{(v + f \delta t) \cos \delta\theta - (\omega + \alpha \delta t)(r + \delta r) \sin \delta\theta - v}{\delta t}$$

In the limit, as  $\delta t \rightarrow 0$ ,  $\cos \delta\theta \rightarrow 1$  and  $\sin \delta\theta \rightarrow \delta\theta$



$$\text{Acceleration of P along AR} = f - \omega r \frac{d\theta}{dt}$$

$$= f - \omega r \omega$$

$$= f - \omega^2 r$$

$$= \text{Acc. of slider} - \text{cent. acc.}$$

This is the acceleration of P along AR in the radially outward direction.

Acceleration of P perpendicular to AR:

$$\text{Initial velocity of P } \perp \text{ to AR} = \omega r$$

$$\text{Final velocity of P } \perp \text{ to AR} = v' \sin \delta\theta + \omega' r' \cos \delta\theta$$

$$\text{Change of velocity } \perp \text{ to AR} = (v' \sin \delta\theta + \omega' r' \cos \delta\theta) - \omega r$$

$$\text{Acceleration of P } \perp \text{ to AR} = \frac{(v + f \delta t) \cos \delta\theta - (\omega + \alpha \delta t)(r + \delta r) \cos \delta\theta - \omega r}{\delta t}$$

In the limit, as  $\delta t \rightarrow 0$ ,  $\cos \delta\theta \rightarrow 1$  and  $\sin \delta\theta \rightarrow \delta\theta$ .

$$\text{Acceleration of P } \perp \text{ to AR} = v \frac{d\theta}{dt} + \omega \frac{dr}{dt} + r\alpha$$

$$= v\omega + \omega v + \alpha r$$

$$= 2\omega v + \alpha r$$

The component  $2\omega v$  is known as the *Coriolis acceleration component*. It is positive if

- (i) the link AR rotates clockwise and the slider moves radially outwards,
- (ii) the link rotates counter-clockwise and the slider moves inwards,

The direction of the coriolis acceleration component is obtained by rotating the radial velocity vector  $v$  through  $90^\circ$  in the direction of rotation of the link.

Coriolis component exist only if there are two coincident points which have, (i) linear relative velocity of sliding and, (ii) angular motion about fixed finite centers of rotation.

Let Q be a point on the link AR immediately beneath the point P at the instant, then ,

Acc. Of P = Acce. Of P || to AR + Acceleration of P  $\perp$  to AR.

$$\vec{f}_{pa} = (f - \omega^2 r) + (2\omega v + r\alpha)$$

$$= f + (r\alpha - \omega^2 r) + 2\omega v$$

= Acc. of P rel. to Q + Acc. of Q rel to A + coriolis acceleration component

$$= f'_{pq} + f_{qa} + f^{cr}$$

Sometimes for sake of simplicity, it is convenient to associate the coriolis acceleration component  $f^{cr}$  with  $f'_{pq}$  and writing the equation in the form,

$$= (f'_{pq} + f^{cr}) + f_{qa}$$



			$\vec{a}_1 q_a$ or $\vec{a}_1 q_a$	
4.	$\vec{f}_{pq}^s$ or $\vec{q}_1 p_q$	—	$\square$ to $\overline{AR}$	—
5.	$\vec{f}_{pq}^{cr}$ or $\vec{p}_q p_1$	$2\omega_1 v_{pq} = 2 \left( \frac{aq}{AQ} \right) qp$	$\perp$ to $\overline{AR}$	*

\*  $\rightarrow$  The direction is obtained by rotating the vector  $v_{pq}$  (or  $\vec{qp}$ ) through  $90^\circ$  in the direction of  $\omega_1$ .

Construction of acceleration diagram as follows:

1. Draw the first vector  $\vec{f}_{po}$  which is completely known.
2. Draw the second vector from the point  $a_1$  (or  $o_1$ ). This vector is completely known.
3. Only the direction of the third vector  $\vec{f}_{qa}^t$  is known. Draw a line  $\perp$  to  $\overline{AQ}$  through the head  $q_a$  of the second vector.
4. As the head of third vector is not available, the fourth vector cannot be added to it. Draw the last vector  $\vec{f}_{pq}^{cr}$  which is completely known. Place this vector in proper direction and sense so that  $p_1$  becomes the head of vector.
5. For the fourth vector, draw a line parallel to  $\overline{AR}$  through the point  $p_q$  of the fifth vector.

The intersection of this line with the line drawn in step 3 locates the point  $q_1$ .

Total acc. of P rel. to Q,  $\vec{f}_{pq} = \vec{q}_1 p_1$ ;

Total acc. of Q rel. to A,  $\vec{f}_{qa} = \vec{a}_1 q_1$ ,

The acc. of R rel. to A is given on  $\vec{a}_1 q_1$  produced such that  $\frac{\vec{a}_1 r_1}{\vec{a}_1 q_1} = \frac{AR}{AQ}$ .

6. Join  $a_1$  and  $q_1$  and extend to  $r_1$ .

Writing the vector equation

$$\vec{f}_{so} = \vec{f}_{sr} + \vec{f}_{ro}$$

or  $\vec{f}_{sg} = \vec{f}_{ro} + \vec{f}_{sr}$

$$= \vec{f}_{ro} + \vec{f}_{sr}^c + \vec{f}_{sr}^t$$

or  $\vec{g}_1 s_1 = \vec{o}_1 r_1 + \vec{r}_1 s_r + \vec{s}_r s_1$

Let us set above vectors in vector table

S.N.	Vector	Magnitude	Direction	Sense
6.	$\vec{f}_{ro}$ or $o_1r_1$	Present in diagram		
7.	$\vec{f}_{sr}^c$ or $r_1s_r$	$\frac{(rs)^2}{RS}$	$\parallel$ to $\overline{RS}$	$\rightarrow R$
8.	$\vec{f}_{sr}^t$ or $s_r s_1$	—	$\perp$ to $\overline{RS}$	—
9.	$\vec{f}_{sg}$ or $g_1 s_1$	—	$\parallel$ to guide bed	—

$\vec{f}_{ro}$  is already available on the acceleration diagram. Complete the vector diagram as usual.

7. Draw  $\vec{f}_{sr}^c$  or  $r_1s_r$  through the head  $r_1$  which is known.

8. For the vector  $\vec{f}_{sr}^t$  or  $s_r s_1$ , draw a perpendicular line with  $\vec{f}_{sr}^c$  or  $r_1s_r$  through the head  $s_1$ .

9. For the vector  $\vec{f}_{sg}$  or  $g_1 s_1$ , draw a horizontal line through  $g_1$ . The intersection point of  $\vec{f}_{sr}^t$  and  $\vec{f}_{sg}$  will be the  $s_1$ .

Angular acceleration of RS is  $\vec{\alpha}_{rs} = \frac{\vec{f}_{sr}^t}{RS}$ .

If the direction of  $\vec{g}_1 s_1$  is opposite to the direction of motion of the slider S then it indicates that the slider is decelerating.

### Algebraic Method:

Vector approach:

Let there be a plane moving body having its motion relative to a fixed coordinate system  $xyz$ . Also let a moving coordinate system  $x'y'z'$  be attached to this moving body. Coordinates of the origin A of the moving system are known relative to the absolute reference system. Assume that the moving system has an angular velocity  $\omega$ .

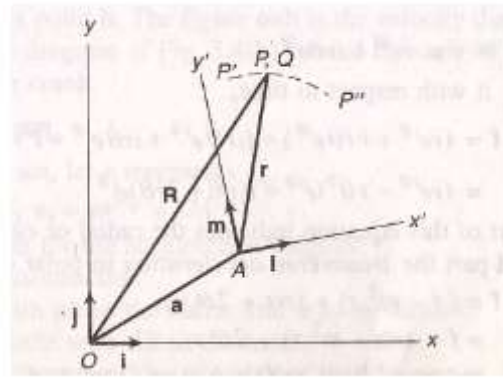

Figure - 35

Let

- $\hat{i}, \hat{j}, \hat{k}$  are the unit vectors of absolute system  
 $\hat{l}, \hat{m}, \hat{n}$  are the unit vectors for the moving system.  
 $\vec{\omega}$  angular velocity of rotation of the moving system,  
 $\vec{R}$  vector relative to fixed system,  
 $\vec{r}$  vector relative to moving system

Let a point P move along path  $P'PP''$  relative to the moving coordinate system  $x'y'z'$ . At any instant, the position of P relative to the fixed system is

$$\vec{R} = \vec{a} + \vec{r} \quad \text{where } \vec{r} = x'\hat{l} + y'\hat{m} + z'\hat{n}$$

$$\Rightarrow \vec{R} = \vec{a} + x'\hat{l} + y'\hat{m} + z'\hat{n}$$

Taking the derivatives with respect to time to find velocity,

$$\dot{\vec{R}} = \dot{\vec{a}} + (\dot{x}'\hat{l} + \dot{y}'\hat{m} + \dot{z}'\hat{n}) + (x'\dot{\hat{l}} + y'\dot{\hat{m}} + z'\dot{\hat{n}})$$

- The term  $\dot{\vec{a}}$  indicates velocity of origin of moving system.
- The second term is known as relative velocity of P with relative to the coincident point Q which is fixed to the moving system. It may be denoted by  $v_{pq}$  or  $v^R$ .

Thus  $\vec{v}_{pq} \text{ or } v^R = \dot{x}'\hat{l} + \dot{y}'\hat{m} + \dot{z}'\hat{n}$

- The third term can be simplified as below:

$$\dot{\hat{l}} = \omega \times \hat{l}, \quad \dot{\hat{m}} = \omega \times \hat{m}, \quad \dot{\hat{n}} = \omega \times \hat{n}$$

$$\therefore (x'\dot{\hat{l}} + y'\dot{\hat{m}} + z'\dot{\hat{n}}) = \omega \times (x'\hat{l} + y'\hat{m} + z'\hat{n}) = \omega \times \vec{r}$$

This is the velocity of Q relative to A and is denoted as  $\vec{v}_{qa}$ . Then we can write

$$\dot{\vec{R}} = \dot{\vec{a}} + \left( \dot{x}' \hat{l} + \dot{y}' \hat{m} + \dot{z}' \hat{n} \right) + \vec{\omega} \times \vec{r}$$

$$\Rightarrow \vec{v}_p = \vec{v}_a + \vec{v}^R + \vec{\omega} \times \vec{r}$$

$$\Rightarrow \vec{v}_{po} = \vec{v}_{ao} + \vec{v}_{pq} + \vec{v}_{qa}$$

$$\Rightarrow \vec{v}_{po} = \vec{v}_{pq} + \vec{v}_{qa} + \vec{v}_{ao}$$

$$\Rightarrow \vec{v}_{po} = \vec{v}_{pq} + \vec{v}_{qo}$$

Thus absolute velocity of point P moving relative to a moving reference system is equal to the velocity of the point relative to the moving system plus the absolute velocity of a coincident point fixed to the moving reference system.

### Acceleration analysis

We know from above discussion that

$$\vec{v}_p = \vec{v}_a + \vec{v}^R + \vec{\omega} \times \vec{r}$$

Differentiating this equation with respect to time to obtain the acceleration of P,

$$\dot{\vec{v}}_p = \dot{\vec{v}}_a + \dot{\vec{v}}^R + \dot{\vec{\omega}} \times \vec{r} + \vec{\omega} \times \dot{\vec{r}}$$

$$\vec{f}_p = \vec{f}_a + \dot{\vec{v}}^R + \dot{\vec{\omega}} \times \vec{r} + \vec{\omega} \times \dot{\vec{r}}$$

Where  $\dot{\vec{\omega}}$  is the angular acceleration of rotation of the moving system.

$$\vec{v}^R = \dot{x}' \hat{l} + \dot{y}' \hat{m} + \dot{z}' \hat{n}$$

Differentiating it w.r.t. time,

$$\dot{\vec{v}}^R = \left( \ddot{x}' \hat{l} + \ddot{y}' \hat{m} + \ddot{z}' \hat{n} \right) + \left( \dot{x}' \dot{\hat{l}} + \dot{y}' \dot{\hat{m}} + \dot{z}' \dot{\hat{n}} \right)$$

$$= \left( \ddot{x}' \hat{l} + \ddot{y}' \hat{m} + \ddot{z}' \hat{n} \right) + \vec{\omega} \times \left( \dot{x}' \hat{l} + \dot{y}' \hat{m} + \dot{z}' \hat{n} \right)$$

$$= \vec{f}^R + \vec{\omega} \times \vec{v}^R$$

$$\vec{\omega} \times \dot{\vec{r}} = \vec{\omega} \times \frac{d}{dt} \left( \dot{x}' \hat{l} + \dot{y}' \hat{m} + \dot{z}' \hat{n} \right)$$

$$= \vec{\omega} \times \left[ \left( \dot{x}' \hat{l} + \dot{y}' \hat{m} + \dot{z}' \hat{n} \right) + \left( \dot{x}' \dot{\hat{l}} + \dot{y}' \dot{\hat{m}} + \dot{z}' \dot{\hat{n}} \right) \right]$$

$$= \vec{\omega} \times \vec{v}^R + \vec{\omega} \times (\vec{\omega} \times \vec{r})$$

Thus we may write

$$\vec{f}_p = \vec{f}_a + \left( \vec{f}^R + \vec{\omega} \times \vec{v}^R \right) + \dot{\vec{\omega}} \times \vec{r} + \left[ \vec{\omega} \times \vec{v}^R + \vec{\omega} \times (\vec{\omega} \times \vec{r}) \right]$$

$$= \vec{f}_a + \vec{f}^R + 2\vec{\omega} \times \vec{v}^R + \dot{\vec{\omega}} \times \vec{r} + \vec{\omega} \times (\vec{\omega} \times \vec{r})$$

Now as  $\vec{f}_{qa} = \dot{\vec{\omega}} \times \vec{r} + \vec{\omega} \times (\vec{\omega} \times \vec{r})$

Thus we can write

$$\vec{f}_p = \vec{f}_a + \vec{f}^R + 2\vec{\omega} \times \vec{v}^R + \vec{f}_{qa}$$

Or  $\vec{f}_{po} = \vec{f}_{ao} + \vec{f}_{pq} + \vec{f}^{cr} + \vec{f}_{qa}$

$$= \vec{f}_{pq} + \vec{f}_{qa} + \vec{f}_{ao} + \vec{f}^{cr}$$

We can write

$$\vec{f}_{pa} + \vec{f}_{ao} = \vec{f}_{pq} + \vec{f}_{qa} + \vec{f}_{ao} + \vec{f}^{cr}$$

$$\Rightarrow \vec{f}_{pa} = \vec{f}_{pq} + \vec{f}_{qa} + \vec{f}^{cr}$$

### Klein's Construction:

In Klein's construction, the velocity and the acceleration diagrams are made on the configuration diagram itself. The line that represents the crank in the configuration diagram also represents the velocity and acceleration of its moving end in the velocity and acceleration diagrams respectively. For the slider crank mechanism, the procedure to make the Klein's construction is described below.

### Slider Crank Mechanism

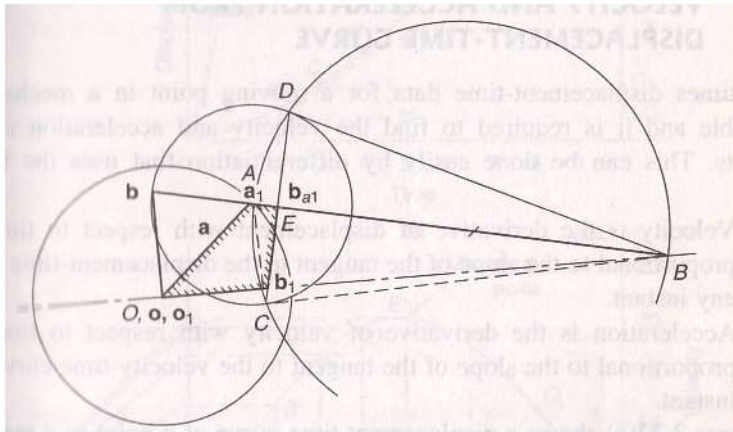

Figure - 36

In the figure OAB represents the configuration of a slider – crank mechanism. Its velocity and acceleration diagrams are shown. Let  $r$  be the length of the crank  $OA$ .

### Velocity diagram:

For velocity diagram, let  $r$  represents  $V_{ao}$  to some scale. Then for the velocity diagram, length  $oa = \omega r = OA$ . From this, the scale for the velocity diagram is known.

Produce  $BA$  and draw a line perpendicular to  $OB$  through  $O$ . The intersection of two lines locates point  $b$ . The figure  $oab$  is the velocity diagram which is similar to the actual velocity diagram rotated through  $90^\circ$  in a direction opposite to that of the crank.

### Acceleration diagram:

For acceleration diagram, let  $r$  represents  $f_{ao}$

$$\therefore o_1a_1 = \omega^2 r = OA$$

This provides the scale for the acceleration diagram.

Make the following construction:

1. Draw a circle with  $ab$  as the radius and  $a$  as the center.
2. Draw another circle with  $AB$  as diameter.
3. Join the points of intersections  $C$  and  $D$  of the two circles. Let it meet  $OB$  at  $b_1$  and  $AB$  at  $E$ .
4. Then  $o_1a_1b_a b_1$  is the required acceleration diagram which is similar to the actual acceleration diagram rotated through  $180^\circ$

The proof is as follows:

Join  $AC$  and  $BC$ .  $AEC$  and  $ABC$  are two right – angled triangles in which angle  $CAB$  is common. Therefore, the triangles are similar.

$$\frac{AE}{AC} = \frac{AC}{AB} \text{ or } AE = \frac{(AC)^2}{AB} \text{ or } a_1b_a = \frac{(ab)^2}{AB} = f_{ba}^c$$

Thus, this acceleration diagram has all the sides parallel to that of acceleration and also has two sides  $o_1a_1$  and  $a_1b_a$  representing the corresponding magnitudes of the acceleration. Thus, the two diagrams are similar.

### **Dynamic Force Analysis:**

Dynamic forces are associated with accelerating masses. In situations where dynamic forces are dominant or comparable with magnitudes of external forces and operating speeds are high, dynamic analysis has to be carried out.

**D’Alembert’s Principle:** The inertia forces and couples and the external forces and torques on a body together give statical equilibrium.

Inertia is a property of matter by virtue of which a body resists any change in velocity.

$$\text{Inertia force } F_i = -mf_g$$

Where  $m$  = mass of body,  $f_g$  = acceleration of center of mass of the body.

- Negative sign indicates that the force acts in the opposite direction to that of acceleration.



- The force acts through center of mass of the body.

Similarly, an inertia couple resists any change in the angular velocity.

Inertia couple,  $C_i = -I_g \alpha$

Where  $I_g$  = moment of inertia about an axis passing through center of mass G and perpendicular to plane of rotation of the body.

$A$  = angular acceleration of the body.

Let  $\sum F = F_1 + F_2 + F_3 + \dots =$  external forces on the body.

and  $\sum T = T_1 + T_2 + T_3 + \dots =$  external torques on the body about the center of mass G. According to D' Alembert's principle,

$$\sum F + F_i = 0 \quad \text{and} \quad \sum T + C_i = 0$$

Thus, a dynamic analysis problem is reduced to one static problem.

### Dynamic analysis of slider – crank mechanism :

#### Velocity and Acceleration of Piston:

Figure shows a slider crank mechanism in which the crank OA rotates in the clockwise direction.  $l$  and  $r$  are the lengths of the connecting rod and the crank respectively.

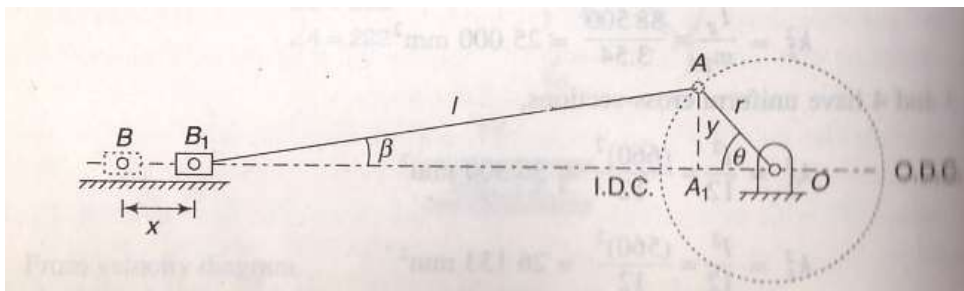

Figure - 37

Let  $x$  = displacement of piston from inner – dead center. At the moment when the crank has turned through angle  $\theta$  from the inner – dead center,

$$\begin{aligned} x &= B_1B = BO - B_1O \\ &= BO - (B_1A_1 + A_1O) \\ &= (l+r) - (l \cos \beta + r \cos \theta) \\ &= (nr + r) - (nr \cos \beta + r \cos \theta) \end{aligned} \quad \left( \text{taking } \frac{l}{r} = n \right)$$

$$= r[(n+1) - (n \cos \beta + \cos \theta)]$$

Where

$$\cos \beta = \sqrt{1 - \sin^2 \beta} = \sqrt{1 - \frac{y^2}{l^2}}$$

$$= \sqrt{1 - \frac{(r \sin \theta)^2}{l^2}} = \sqrt{1 - \frac{\sin^2 \theta}{n^2}}$$

$$= \frac{1}{n} \sqrt{n^2 - \sin^2 \theta}$$

$$x = r[(n+1) - (\sqrt{n^2 - \sin^2 \theta} + \cos \theta)]$$

$$= r[(1 - \cos \theta) + (n - \sqrt{n^2 - \sin^2 \theta})]$$

If the connecting rod is very large as compared to crank,  $n^2$  will be large and the maximum value of  $\sin^2 \theta$  can be unity. Then  $\sqrt{n^2 - \sin^2 \theta}$  will be approaching  $\sqrt{n^2}$  or  $n$ , and  $x = r(1 - \cos \theta)$

This is the expression for simple harmonic motion. Thus the piston executes a simple harmonic motion when the connecting rod is large.

Velocity of piston:

$$v = \frac{dx}{dt} = \frac{dx}{d\theta} \frac{d\theta}{dt}$$

$$= \frac{d}{d\theta} \left[ r \left\{ (1 - \cos \theta) + n - (n^2 - \sin^2 \theta)^{1/2} \right\} \right] \frac{d\theta}{dt}$$

$$= r \left[ (0 + \sin \theta) + 0 - \frac{1}{2} (n^2 - \sin^2 \theta)^{1/2} (-2 \sin \theta \cos \theta) \right] \omega$$

$$= r\omega \left[ \sin \theta + \frac{\sin 2\theta}{2\sqrt{n^2 - \sin^2 \theta}} \right]$$

If  $n^2$  is large compared to  $v = r\omega \left[ \sin \theta + \frac{\sin 2\theta}{2n} \right]$

If  $\frac{\sin 2\theta}{2n}$  can be neglected (when is quite large).

$$v = r\omega \sin \theta$$

Acceleration of Piston:

$$\begin{aligned}
f &= \frac{dv}{dt} = \frac{dv}{d\theta} \frac{d\theta}{dt} \\
&= \frac{d}{d\theta} \left[ r\omega \left( \sin\theta + \frac{\sin 2\theta}{2n} \right) \right] \omega \\
&= r\omega \left( \cos\theta + \frac{2\cos 2\theta}{2n} \right) \omega \\
&= r\omega^2 \left( \cos\theta + \frac{\cos 2\theta}{n} \right)
\end{aligned}$$

If  $n$  is very very large,

$$f = r\omega^2 \cos\theta \text{ as in case of SHM}$$

When  $\theta = 0^\circ$  i.e. at IDC,  $f = r\omega^2 \left( 1 + \frac{1}{n} \right)$

When  $\theta = 180^\circ$ , i.e. at ODC,  $f = r\omega^2 \left( -1 + \frac{1}{n} \right)$

At  $\theta = 180^\circ$ , when the direction of motion is reversed,  $f = r\omega^2 \left( 1 - \frac{1}{n} \right)$

Note that this expression of acceleration has been obtained by differentiating the approximate expression for the velocity. It is, usually, very cumbersome to differentiate the exact expression for velocity.

Angular velocity and angular acceleration of connecting rod:

As  $y = l \sin\beta = r \sin\theta$

$\therefore \sin\beta = \frac{\sin\theta}{n} \quad \left( n = \frac{l}{r} \right)$

Differentiating with respect to time,

$$\cos\beta \frac{d\beta}{dt} = \frac{1}{n} \cos\theta \frac{d\theta}{dt}$$

or  $\omega_c = \omega \frac{\cos\theta}{n \frac{1}{n} \sqrt{n^2 - \sin^2\theta}}$

where  $\omega_c$  is the angular velocity of the connecting rod

or 
$$\omega_c = \omega \frac{\cos \theta}{\sqrt{n^2 - \sin^2 \theta}}$$

Let  $\alpha_c =$  angular acceleration of the connecting rod

$$\begin{aligned} &= \frac{d\omega_c}{dt} = \frac{d\omega_c}{d\theta} \frac{d\theta}{dt} \\ &= \omega \frac{d}{d\theta} \left[ \cos \theta (n^2 - \sin^2 \theta)^{-1/2} \right] \omega \\ &= \omega^2 \left[ -\cos \theta \frac{1}{2} (n^2 - \sin^2 \theta)^{-3/2} (-2 \sin \theta \cos \theta) + (n^2 - \sin^2 \theta)^{-1/2} (-\sin \theta) \right] \\ &= \omega^2 \sin \theta \left[ \frac{\cos^2 \theta - (n^2 - \sin^2 \theta)}{(n^2 - \sin^2 \theta)^{3/2}} \right] \\ &= -\omega^2 \sin \theta \left[ \frac{n^2 - 1}{(n^2 - \sin^2 \theta)^{3/2}} \right] \end{aligned}$$

The negative sign indicates that the sense of angular acceleration of the rod is such that it tends to reduce the angle  $\beta$ .

### Engine Force Analysis:

An engine is acted upon by various forces such as weight of reciprocating masses and connecting rod, gas forces, forces due to friction and inertia forces due to acceleration and retardation of engine elements, the last being dynamic in nature. The analysis is made of the forces neglecting the effect of the weight and the inertia effect of the connecting rod.

#### (i) Piston Effort ( effective driving force):

Piston effort is termed as the net or effective force applied on the piston. In reciprocating engines, the reciprocating masses accelerate during the first half of the stroke and the inertia force tends to resist the same. Thus the net force on the piston is decreased. During the later half of the stroke, the reciprocating masses decelerate and the inertia force opposes this deceleration or acts in the direction of the applied gas pressure and thus, increases the effective force on the piston.

In vertical engine, the weight of the reciprocating masses assists the piston during the down stroke, thus, increases the piston effort by an amount equal the weight of the piston. During the upstroke, piston effort is decreased by the same amount.

Let  $A_1$  = area of the cover end  
 $A_2$  = area of the piston rod end  
 $p_1$  = pressure on the cover end  
 $p_2$  = pressure on the rods end  
 $m$  = mass of the reciprocating parts

Force on the piston due to the gas pressure,  $F_p = p_1A_1 - p_2A_2$

Inertia force,  $F_b = mf = mr\omega^2 \left( \cos \theta + \frac{\cos 2\theta}{n} \right)$ . It is opposite direction to that of the acceleration of the piston.

Resistant force =  $F_f$

Net effective force on the piston,  $F = F_p - F_b - F_f$

In case vertical engines, the weight of the piston or reciprocating parts also acts.

Force on the piston,  $F = F_p + mg - F_b - F_f$

(ii) Force (thrust) along the Connecting rod:

Let  $F_c$  = Force in the connecting rod

Then equating the horizontal components of forces,

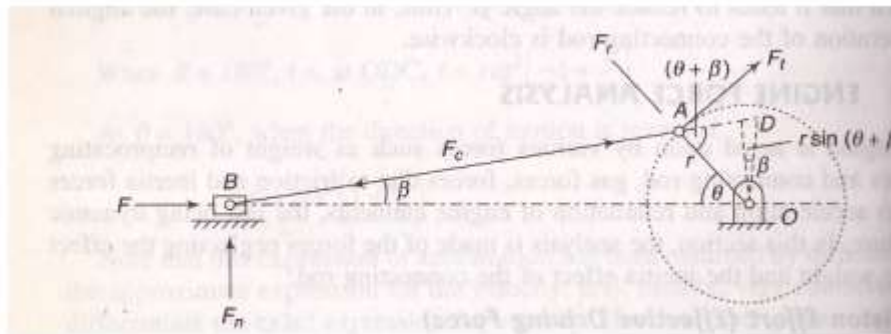

Figure - 38

$$F_c \times \cos \beta = F \text{ or } F_c = \frac{F}{\cos \beta}$$

(iii) Thrust on the Sides of Cylinder

It is the normal reaction on the cylinder walls.

$$F_n = F_c \sin \beta = F \tan \beta$$

(iv) Crank Effort

Force is exerted on the crank pin as a result of the force on the piston. Crank effort is the net effort applied at the crank pin perpendicular to the crank which gives the required turning moment on the crankshaft.

Let  $F_t$  = crank effort

$$\begin{aligned} \text{As } F_t \times r &= F_c \times r \times \sin(\theta + \beta) \\ &= \frac{F}{\cos \beta} \sin(\theta + \beta) \end{aligned}$$

(v) Thrust on the Bearings

The component of  $F_c$  along the crank (in the radial direction) produces a thrust on the crankshaft bearings.

$$F_r = F_c \cos(\theta + \beta) = \frac{F}{\cos \beta} \cos(\theta + \beta)$$

Turning moment on Crankshaft:

$$\begin{aligned} T &= F_t \times r \\ &= \frac{F}{\cos \beta} \sin(\theta + \beta) \times r = \frac{Fr}{\cos \beta} (\sin \theta \cos \beta + \cos \theta \sin \beta) \\ &= Fr \left( \sin \theta + \cos \theta \sin \beta \frac{1}{\cos \beta} \right) \\ &= Fr \left( \sin \theta + \cos \theta \frac{\sin \theta}{n} \frac{1}{\frac{1}{n} \sqrt{n^2 - \sin^2 \theta}} \right) \\ &= Fr \left( \sin \theta + \frac{2 \sin \theta \cos \theta}{2 \sqrt{n^2 - \sin^2 \theta}} \right) \\ &= Fr \left( \sin \theta + \frac{\sin 2\theta}{2 \sqrt{n^2 - \sin^2 \theta}} \right) \end{aligned}$$

Also as  $r \sin(\theta + \beta) = OD \cos \beta$

$$\begin{aligned} T &= F_t \times r \\ &= \frac{F}{\cos \beta} r \sin(\theta + \beta) \end{aligned}$$

$$= \frac{F}{\cos \beta} (OD \cos \beta)$$

$$= F \times OD$$

### Dynamically Equivalent System:

As neither the mass of the connecting rod is uniformly distributed nor the motion is linear, its inertia cannot be found in a general manner.

Usually, the inertia of the connecting rod is taken into account by considering a dynamically – equivalent system.

Dynamically–equivalent system means that the rigid link is replaced by a link with two point masses in such a way that it has the same motion as the rigid link when subjected to the same force i.e. the center of mass of the equivalent link has the same linear acceleration and the link has the same angular acceleration.

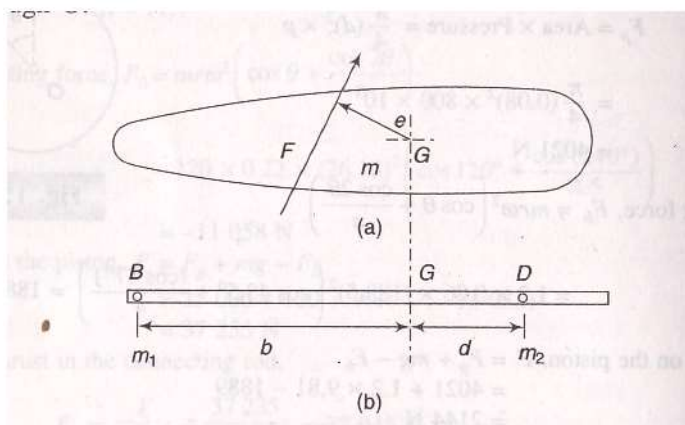

Figure - 39

Figure 39 (a) shows a rigid body of mass 'm' with center of mass at G. Let a force F is acting on body and the line of action is e distance from the C.G..

As we know  $\vec{F} = m \cdot \vec{f}$

and  $\vec{F} \cdot e = I \cdot \vec{\alpha}$

Acc. of G,  $\vec{f} = \frac{\vec{F}}{m}$

Angular acc. ,  $\vec{\alpha} = \frac{\vec{F} \cdot e}{I}$

Where,  $e =$  perpendicular distance of F from G.

$I =$  moment of inertia of the body about perpendicular axis  
through G.

Now to have the dynamically equivalent system, let the replaced massless link has two point masses ( $m_1$  at B and  $m_2$  at D) at distances  $b$  and  $d$  respectively from the center of mass G.

1. To satisfy same acceleration, the sum of the equivalent masses  $m_1$  and  $m_2$  has to be equal to  $m$ .

$$\Rightarrow m = m_1 + m_2$$

2. To satisfy same angular acceleration  $\frac{\vec{F} \cdot e}{I}$  should be same.

(i)  $\vec{F}$  is already taken same, thus  $e$  has to be same which means that the combined center of mass of the equivalent system remains at G. This is possible if

$$m_1 \cdot b = m_2 \cdot d$$

(ii) To have the same moment of inertia of the equivalent system about perpendicular axis through their combined center of mass G, we must have

$$I = m_1 \cdot b^2 + m_2 \cdot d^2$$

Thus any distributed mass can be replaced by two point masses to have the same dynamical properties if the following conditions fulfilled.

- (a) The sum of two masses is equal to the total mass.
- (b) The combined center of mass coincides with that of rod.
- (c) The moment of inertia of two point masses about perpendicular axis through their combined center of mass is equal to that of the rod.

Inertia of the connecting rod:

Let the connecting rod be replaced by an equivalent massless link with two point masses as shown.

Let  $m$  be the total mass of the connecting rod and one of the masses be located at the small end B. Let the second mass be placed at D.



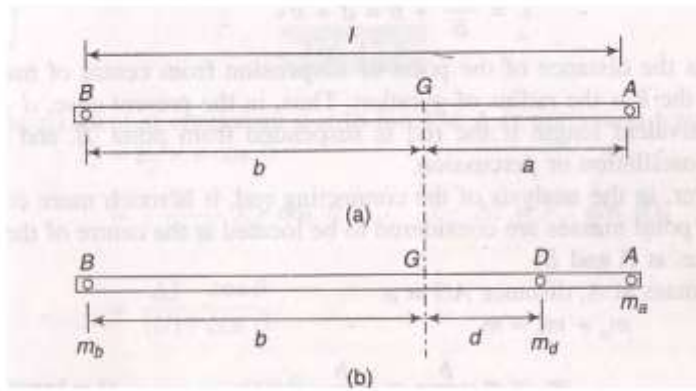

Figure - 40

$m_b$  = mass at B,  $m_d$  = mass at D

Take  $BG = b$  and  $DG = d$

Then  $m_b + m_d = m$

$$m_b \cdot b = m_d \cdot d$$

From above these two equations we can get

$$m_b + \left( m_b \frac{b}{d} \right) = m$$

$$\Rightarrow m_b \left( 1 + \frac{b}{d} \right) = m$$

$$\Rightarrow m_b \left( \frac{b+d}{d} \right) = m$$

$$\Rightarrow m_b = m \frac{d}{b+d}$$

Similarly  $m_d = m \frac{b}{b+d}$

Hence  $I = m_b b^2 + m_d d^2$

$$= m \frac{d}{b+d} b^2 + m \frac{b}{b+d} d^2$$

$$= mbd \left( \frac{b+d}{b+d} \right)$$

$$= mbd$$

Let  $k$  = radius of gyration of the connecting rod about an axis through center of mass  $G$  perpendicular to the plane of motion.

$$mk^2 = mbd$$

$$\Rightarrow k^2 = bd$$

This result can be compared with that of an equivalent length of a simple pendulum in the following manner :

The equivalent length of a simple pendulum is given by

$$L = \frac{k^2}{b} + b = d + b$$

Where  $b$  is the distance of the point of suspension from center of mass of the body and the  $k$  is the radius of gyration. Thus , in the present case ,  $d + b (= L)$  is the equivalent length if the rod is suspended from point B, and  $d$  is the center of oscillation or percussion.

However, in the analysis of the connecting rod, it is much more convenient if the two point masses are considered to be located at the center of the two end bearings i.e. at A and B.

Let  $m_a$  = mass at A, distance AG =  $a$

$$\Rightarrow m_a + m_b = m$$

$$\Rightarrow m_a = m \frac{b}{a+b} = m \frac{b}{l}$$

Similarly  $m_b = m \frac{a}{a+b} = m \frac{a}{l}$

$$I' = mab$$

Assuming ,  $a > d$  ,  $\Rightarrow I' > I$

This means that by considering the two masses at A and B instead of at D and B, the inertia torque is increased from the actual value  $T (= I\alpha)$ . The error is corrected by incorporating a correction couple.

Then correction couple is

$$\Delta T = \alpha_c (mab - mbd)$$

$$= mb\alpha_c (a - d)$$

$$= mb\alpha_c [(a+b) - (b+d)]$$

$$= mb\alpha_c (l-L) \quad (\text{taking } b+d=L)$$

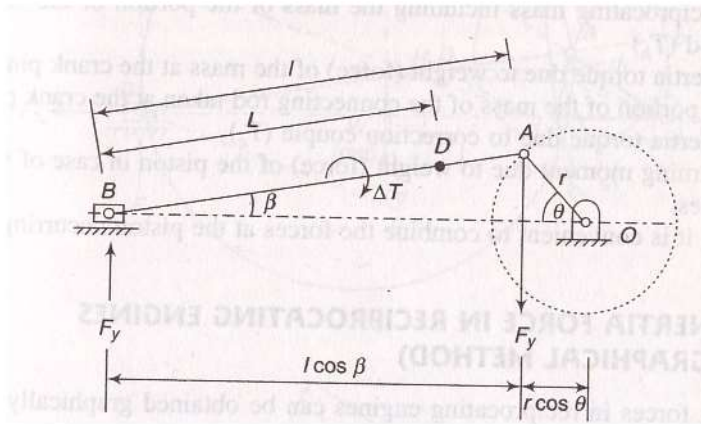

Figure - 41

This correction couple must be applied in the opposite direction to that of the applied inertia torque. As the direction of the applied inertia torque is always opposite to the direction of the angular acceleration, the direction of the correction couple will be the same as that of angular acceleration i.e. in the direction of decreasing angle  $\beta$ .

### Pivots and Collars:

When a rotating shaft is subjected to an axial load the thrust (axial force) is taken either by a pivot or a collar.

Collar Bearing: A collar bearing or simply a collar is provided at any position along the shaft and bears the axial load on a mating surface. The surface of the collar may be plane (flat) normal to the shaft or of conical shape.

Pivot bearing: When the axial load is taken by the end of the shaft which is inserted in a recess to bear the thrust, it is called a pivot bearing or simply a pivot. It is also known as foot step bearing. The surface of the pivot can also be flat or of conical shape.

### Uniform pressure and uniform wear:

Friction torque of a collar or a pivot bearing is calculated, usually on the basis of two assumptions. In one case it is assumed that the intensity of pressure on the bearing surface is constant, where as in 2<sup>nd</sup> case, it is the uniform wearing of the bearing surface.

For uniform pressure :-

$$\text{Pressure} = \frac{\text{axial force}}{\text{cross sectional area}}$$

$$P = \frac{F}{\pi(R_o^2 - R_i^2)}$$

For uniform wear:-

Let  $p_1$  = normal pressure between two surfaces at radius  $r_1$

$p_2$  = normal pressure between two surfaces at radius  $r_2$

$b$  = width of the surface at radii  $r_1$  and  $r_2$

$$p_1 \times \text{area at } r_1 \times \mu_w = p_2 \times \text{area at } r_2 \times \mu_w$$

$$\Rightarrow p_1 \times 2\pi r_1 \times b = p_2 \times 2\pi r_2 \times b$$

$$\Rightarrow p_1 r_1 = p_2 r_2$$

$$\Rightarrow pr = \text{constant } (C)$$

Thus in case of uniform weariness of the two surfaces, product of the normal pressure and the corresponding radius must be constant. Pressure on an elemental area at radius  $r$  can be found as given below.

$$\begin{aligned} \text{Axial force, } F &= \int_{R_i}^{R_o} \text{Axial force on the elemental area} \\ &= \int_{R_i}^{R_o} \text{Pressure on the element} \times \text{Area} \\ &= \int_{R_i}^{R_o} p \times 2\pi r \times dr \\ &= \int_{R_i}^{R_o} \frac{C}{r} \times 2\pi r dr \\ &= \int_{R_i}^{R_o} 2\pi C dr \quad = 2\pi C r \Big|_{R_i}^{R_o} \quad = 2\pi C (R_o - R_i) \\ &= 2\pi pr (R_o - R_i) \\ \Rightarrow p &= \frac{F}{2\pi r (R_o - R_i)} \end{aligned}$$

Collars and pivots, using the above two theories have been analysed below.

Collars:

(i) Flat collars:

Let  $p$  = uniform normal pressure over an area

$F$  = axial thrust

$N$  = speed of the shaft

$\mu$  = coefficient of friction between two surfaces

Consider an element of width  $\delta r$  of the collar at radius  $r$ . Friction on the element

$$\begin{aligned}\delta F &= \mu \times \text{axial force} \\ &= \mu \times p \times \text{area of the element} \\ &= \mu \times p \times 2\pi r \delta r\end{aligned}$$

Friction torque about the shaft axis

$$\begin{aligned}\delta T &= \delta F \times r \\ &= \mu \times p \times 2\pi r \delta r \times r \\ &= 2\mu p \pi r^2 \delta r\end{aligned}$$

Total friction torque  $T = \int_{R_i}^{R_o} 2\mu p \pi r^2 dr$

(a) With uniform pressure theory: Pressure is uniform over the whole area and is given by

$$\begin{aligned}p &= \frac{F}{\pi(R_o^2 - R_i^2)} \\ T &= \int_{R_i}^{R_o} 2\mu p \pi r^2 \frac{F}{\pi(R_o^2 - R_i^2)} dr \\ &= \int_{R_i}^{R_o} \frac{2\mu F}{(R_o^2 - R_i^2)} r^2 dr \\ &= \frac{2\mu F}{(R_o^2 - R_i^2)} \times \frac{r^3}{3} \Bigg|_{R_i}^{R_o} = \frac{2\mu F (R_o^3 - R_i^3)}{3(R_o^2 - R_i^2)}\end{aligned}$$

(b) With uniform wear theory pressure  $p$  at a radius  $r$  of the collar is given by

$$\begin{aligned}p &= \frac{F}{2\pi r (R_o - R_i)} \\ T &= \int_{R_i}^{R_o} 2\mu \pi r^2 \frac{F}{2\pi r (R_o - R_i)} dr \\ &= \int_{R_i}^{R_o} \frac{\mu F r}{(R_o - R_i)} dr \\ &= \frac{\mu F (R_o^2 - R_i^2)}{2(R_o - R_i)} \\ &= \frac{\mu F}{2} (R_o + R_i)\end{aligned}$$

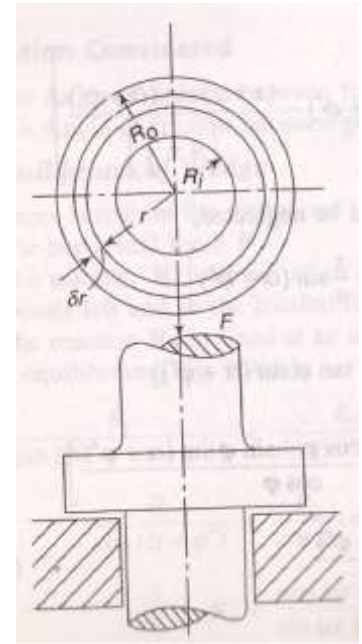

Figure - 42

$$= \mu F \times \text{mean radius of the collar bearing}$$

(ii) Conical collar (Frustrum of cone)

Consider an elementary area of width  $\delta r$  at a radius  $r$  of the bearing. Normal force on the elementary area

$$= \frac{\text{Axial force}}{\sin \alpha}$$

Normal pressure on the elementary area

$$= \frac{\text{Axial force}}{\sin \alpha} \times \frac{1}{\text{surface area}}$$

$$= \frac{\text{Axial force}}{\sin \alpha} \times \frac{1}{2\pi r \delta r / \sin \alpha}$$

$$= \frac{\text{Axial force}}{2\pi r \delta r}$$

$$= \frac{\text{Axial force}}{\text{Area } \perp \text{ to the axial force}}$$

$$= \text{Axial pressure (P)}$$

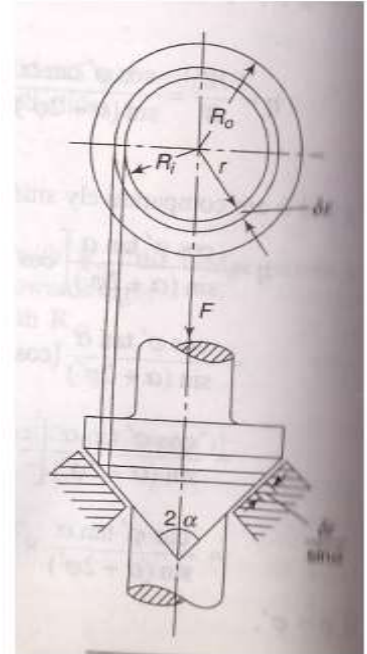

Figure - 43

i.e. normal pressure on the surface is equal to the axial pressure on a flat collar surface.

Friction force on the element

$$\delta F = \mu \times P \times \text{area of the element}$$

$$= \mu \times p \times 2\pi r \frac{\delta r}{\sin \alpha}$$

Friction Torque about the shaft axis

$$\delta T = \delta F \times r$$

$$= \frac{2\mu p \pi r^2}{\sin \alpha} \delta r$$

Total Friction torque

$$T = \int_{R_i}^{R_o} \frac{2\mu p \pi r^2}{\sin \alpha} \delta r$$

(a) With Uniform pressure Theory

$$\begin{aligned}
T &= \int_{R_i}^{R_o} \frac{2\mu \pi r^2}{\sin \alpha} \frac{F}{\pi(R_o^2 - R_i^2)} dr \\
&= \frac{2\mu F}{\sin \alpha (R_o^2 - R_i^2)} \left[ \frac{r^3}{3} \right]_{R_i}^{R_o} \\
&= \frac{2\mu F (R_o^3 - R_i^3)}{3 \sin \alpha (R_o^2 - R_i^2)}
\end{aligned}$$

i.e. the torque is increased in the ratio  $\frac{1}{\sin \alpha}$  from that for flat collars.

(b) With Uniform wear Theory

$$\begin{aligned}
T &= \int_{R_i}^{R_o} \frac{2\mu \pi r^2}{\sin \alpha} \frac{F}{2\pi r (R_o - R_i)} dr \\
&= \int_{R_i}^{R_o} \frac{\mu F}{\sin \alpha (R_o - R_i)} r dr \\
&= \frac{\mu F}{\sin \alpha (R_o - R_i)} \left[ \frac{r^2}{2} \right]_{R_i}^{R_o} \\
&= \frac{\mu F}{2 \sin \alpha} (R_o + R_i) \\
&= \frac{\mu F}{\sin \alpha} \times \text{Mean radius of bearing}
\end{aligned}$$

i.e. the torque is increased by  $\frac{1}{\sin \alpha}$  times from that for flat collars.

Pivots:

Expressions for torque in case of pivots can directly be obtained from the expressions for collars by inserting the values  $R_i = 0$  and  $R_o = R$

(i) Flat Pivot

(a) uniform Pressure theory ,  $T = \frac{2}{3} \mu FR$

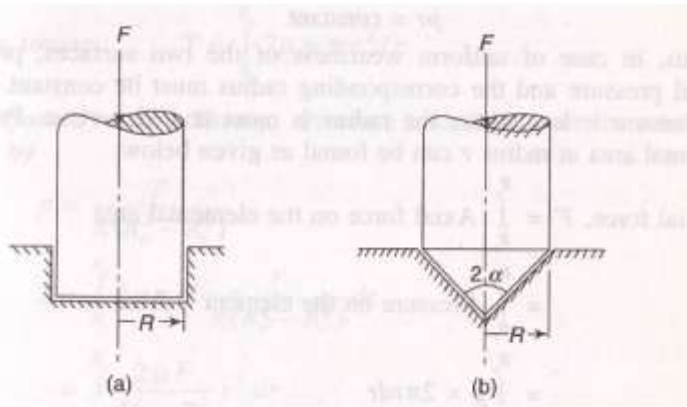

Figure - 44

(b) Uniform wear theory,  $T = \frac{1}{2} \mu FR$

(ii) Conical Pivot

(a) uniform Pressure theory,  $T = \frac{2}{3} \mu \frac{FR}{\sin \alpha}$

(b) Uniform wear theory,  $T = \frac{1}{2} \mu \frac{FR}{\sin \alpha}$

The above equation reveals that the value of the friction torque is more when the uniform pressure theory is applied. In practice, however it has been found that the value of the friction torque lies in between that given by the two theories. To be on the safe side, out of the two theories, one is selected on the basis of use. Thus clutch will surely be transmitting torque given by the uniform wear theory.

On the other hand , while calculating the power loss in a bearing, it is to be on the basis of uniform pressure theory.

Friction clutch

A clutch is a device used to transmit the rotary motion of one shaft to another when desired. The axes of the two shafts are coincident.

In friction clutches the connection of the engine shaft to the gear box shaft is affected by friction between two or more rotating concentric surfaces. The surfaces can be pressed firmly against one another when engaged and the clutch tends to rotate as a single unit.

1. Disc clutch ( single – plate clutch)

A disc clutch consist of a clutch plate attached to a splined hub which is free to slide axially on splines cut on the driven shaft. The clutch plate is made of steel and has a ring friction lining on each side. The engine shaft supports a rigidly fixed fly wheel.



A spring loaded pressure plate presses the clutch plate firmly against the flywheel when clutch is engaged. When disengaged, the spring press against a cover attached to the fly wheel. Thus both the fly wheel and pressure plate rotate with the input shaft. The movement of the clutch plate is transferred to the pressure plate through a throat bearing.

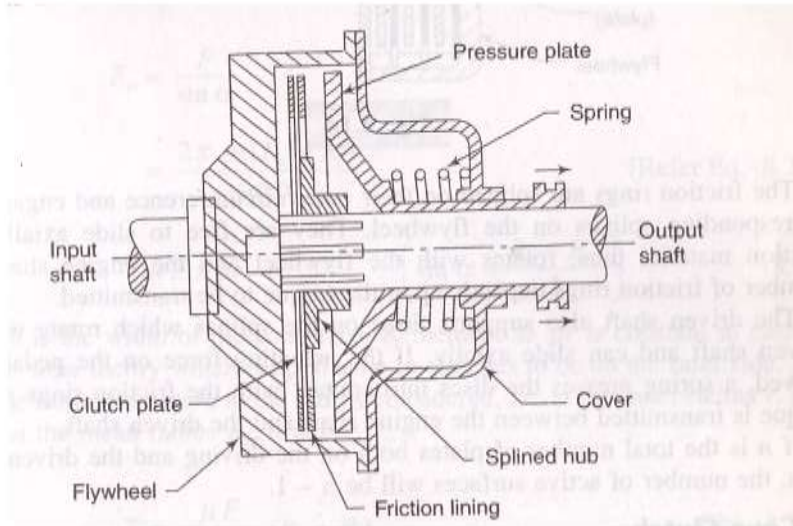

Figure - 45

Figure - 45 shows the pressure plate pulled back by the release levers and the friction linings on the clutch plate are no longer in contact with the pressure plate or the fly wheel. The fly wheel rotates without driving the clutch plate and thus the driven shaft.

When the foot is taken off from the clutch pedal, the pressure on the throat bearing is released. As a result the spring become free to move the pressure plate to bring it in contact with the clutch plate. The clutch plate slide on the splined hub and is tightly gripped between the pressure plate and the fly wheel. The friction between the lining on the clutch plate and the fly wheel on one side and the pressure plate on the other cause the clutch plate and hence the driven shaft to rotate. In case the resisting torque on the driven shaft exceeds the torque at the clutch, clutch slip will occur.

## 2. Multiple plate clutch

In multiple clutch, the number of frictional lining s and the metal plates are increased which increases the capacity of the clutch to transmit torque. Fig shows simplification diagram.

The friction rings are splined on their outer circumference and engage with corresponding splines on the flywheel. They are free to slide axially. The friction

material thus, rotates with the fly wheel and the engine shaft. The number of friction rings depends upon the torque to be transmitted.

The driven shaft also supports disc on the splines which rotate with the driven shaft and can slide axially. If the actuating force on the pedal is removed, a spring presses the discs into contact with the friction rings and torque is transmitted between the engine shaft and the driven shaft.

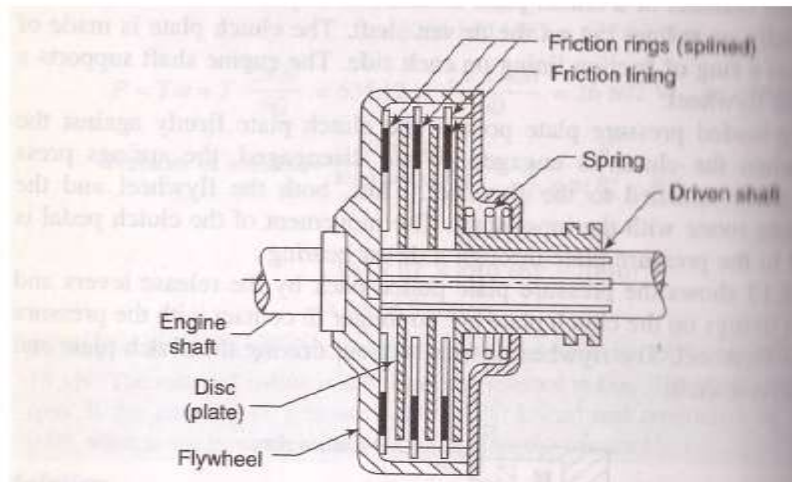

Figure - 46

If  $n_1$  is the number of plates on driving and  $n_2$  is the number of plates on driven shaft the number of active surfaces will be  $n = n_1 + n_2 - 1$

### Cone clutch

In a cone clutch, the contact surfaces are in the form of cones. In the engaged position, the friction surfaces of the two cones A and B are in complete contact due to spring pressure that keeps one cones pressure against the other all the time.

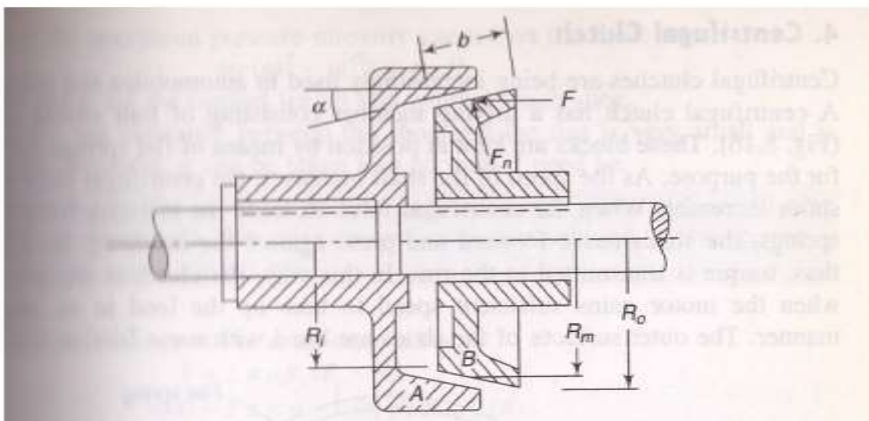

Figure -47

When the clutch is engaged the torque is transmitted from the driving shaft to the driven shaft through the flywheel and the friction cones.

For disengaged the clutch, the cone B is pulled back though a lever system against the force of the spring.

The advantage of a cone clutch is that the normal forces on the contact surfaces is increased. If F is the axial forces,  $F_n$  is the normal force and  $\alpha$  is the semi cone angle of the clutch, then for a conical collar with uniform wear theory.

$$\begin{aligned}
 F_n &= \frac{F}{\sin \alpha} \\
 &= \frac{2\pi pr(R_o - R_i)}{\sin \alpha} \\
 &= 2\pi pr b \qquad \qquad \qquad \sin \alpha = \frac{R_o - R_i}{b}
 \end{aligned}$$

Where b is the width of the cone face. Remember as  $p_r$  is constant in case of uniform wear theory which is applicable to clutches be on the safer side, P is to be normal pressure at the radius considered i.e. at the inner radius  $r_i$  it is  $P_i$  and at the mean radius  $R_m$  it is  $p_m$ .

We know,

$$\begin{aligned}
 T &= \frac{\mu F}{2\sin \alpha} (R_o + R_i) \\
 &= \frac{\mu F_n \sin \alpha}{\sin \alpha} \left( \frac{R_o + R_i}{2} \right) \\
 &= \mu F_n R_m
 \end{aligned}$$

Engagement force is required

$$\begin{aligned}
 F'_1 &= F + \mu F_n \cos \alpha \\
 &= F_n \sin \alpha + \mu F_n \cos \alpha \\
 &= F_n (\sin \alpha + \mu \cos \alpha) \\
 F_e &= F_n (\sin \alpha + \mu \cos \alpha) \\
 F_d &= F_n (\mu \cos \alpha - \sin \alpha)
 \end{aligned}$$

Friction circle

Boundary friction occurs in heavily loaded, slow running bearings. In the type of friction, the frictional force is assumed to be proportional to the normal reaction.

When a shaft rest in the bearing, its weight  $W$  acts through its center of gravity. The reaction of the bearing acts in line with  $W$  in the vertically upward direction. The shaft rests at the bottom of the bearing at A and metal to metal contact between the two.

When a torque is applied to the shaft it rotates and the seat of pressure creeps or climbs up the bearing in a direction opposite to that of rotation. Metal to metal condition still exists and boundary friction criterion applies as the oil film will be of molecular thickness .The common normal at B between the two surfaces in contact passes through the centre of the shaft.

Let  $R_o =$  normal ( radial ) reaction at B

$\mu R_n =$  Frictional force, tangential to the shaft.

The normal reaction and the friction force can be combined into a resultant reaction  $R$  inclined at an angle  $\phi$  to  $R_n$  .

Now the shaft is in equilibrium under the following forces

- (i) Weight  $W$ , acting vertically downwards and
- (ii) Reaction  $R$ .

For equilibrium,  $R$  must act vertically upwards and must be equal to  $W$ . How ever the two forces  $W$  and  $R$  will be parallel and constitute couple.

Let  $OC =$  perpendicular to  $R$  from  $O$

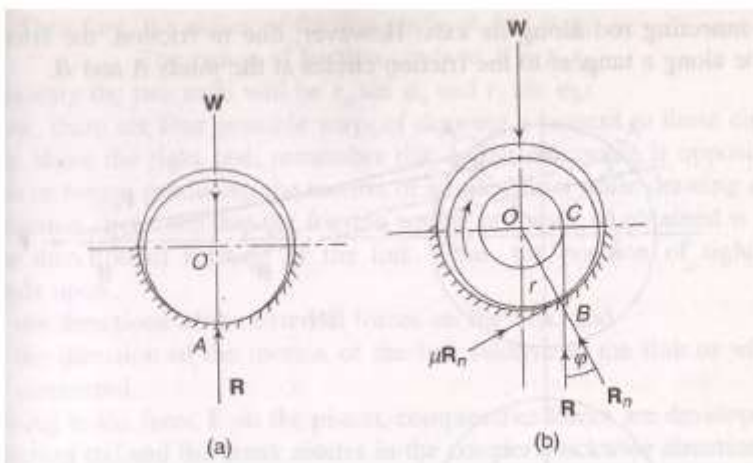

Figure - 48

Friction couple (Torque) =  $Wr \sin \phi$

$$= Wr \tan \phi$$

$$= W r \mu$$

The couple must act opposite to the torque producing motion.

A circle drawn with  $OC$  (or  $r \sin \phi \approx r\mu$ ) as radial is known as the friction circle of the journal bearing.

### Friction axis of a link

In a pin jointed mechanism, usually, it is assumed that the resulting thrusts axial force in the link act along the longitudinal axes of the friction at pin joint acts in the same way as that for a journal revolving in a bearing. In a journal bearing, the resultant force on a journal is tangential to the friction circle. Similarly in pin joint links, the line of thrust on a link is tangential to the friction circles at the pin joints. The net effect of all this is to shift the axes along which the thrust acts. The new axis is known as the friction axis of the link.

### Slider-Crank mechanism

Fig shows a slider – crank mechanism in which  $F$  is the thrust on the slider. If the effect of friction is neglected the force  $F$  will induce a thrust  $F_c$  in the connecting rod along its axis. If the effect of friction is neglected the force  $F$  will induce a thrust  $F_c$  in the connecting rod along its axis. This thrust  $F_c$  will be along a tangent to the friction circles at the joints  $A$  and  $B$ .

$r_a$  = radius of pin at  $A$

$r_b$  = radius of pin at  $B$

$\mu_a$  = coefficient of friction at  $A$

$\mu_b$  = coefficient of friction at  $B$ .

therefore,

the radius of friction circle at  $A = \mu_a r_a$

the radius of friction circle at  $B = \mu_b r_b$

Now there are four possible ways of drawing a tangent to these circles.

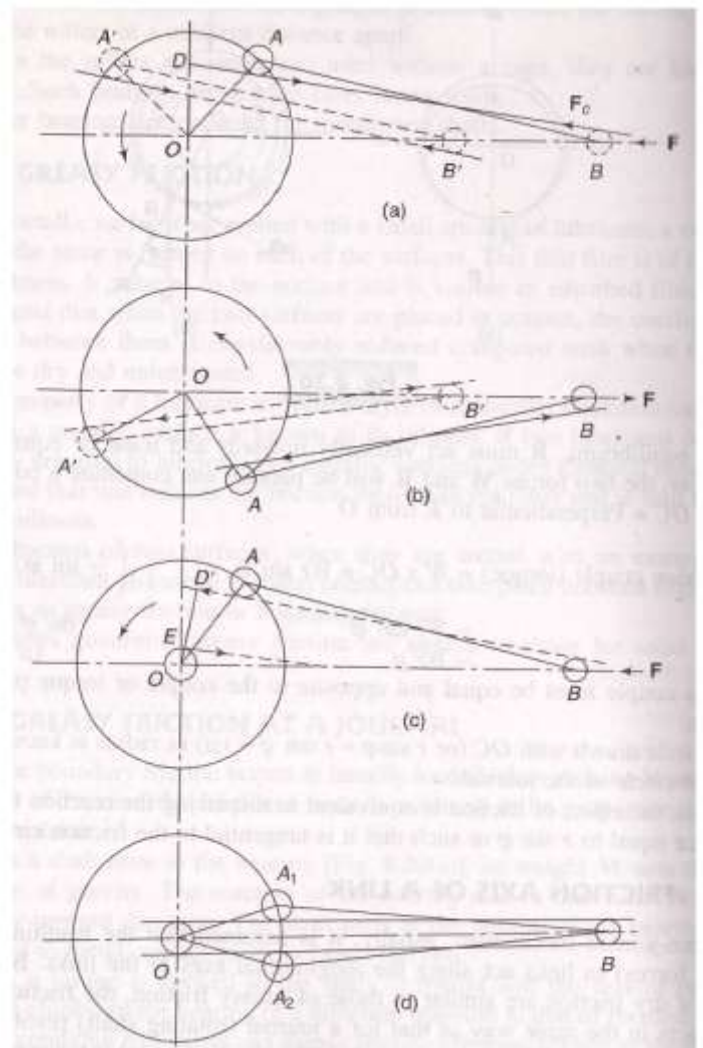

Figure - 49

To decide about the right one, remember that a friction couple is opposite to the couple or torque producing the motion of a link. Thus while drawing a tangent to a friction circle see that the friction couple or torque so obtained is opposite to the direction of rotation of the link. Thus the position of right tangent depends upon

1. The direction of external force on the link.
2. The direction of the motion of the link relative to the link to which it is connected.

### **Gear Trains**

A gear train is a combination of gears used to transmit motion from one shaft to another. It becomes necessary when it is required to obtain large speed reduction within a small space.

The following are the main types of gear trains:

1. Simple gear trains
2. compound gear trains
3. reverted gear train
4. planetary or epicyclic gear trains.

In simple gear trains each shaft supports one gear. In compound gear train each shaft supports two gear wheels except the first and the last. In a reverted gear train, the driving and the driven gears are coaxial or coincident. In all these three types the axes of rotation of the wheels are fixed in position and the gears rotate about their respective axes.

In planetary or epicyclic gear trains the axes of some of the wheels are not fixed but rotate around the axes of other wheels with useful to transmit very high velocity ratios with gears of smaller sizes in a lesser space.

#### **Simple gear trains**

A series of gears, capable of receiving and transmitting motion from one gear to another is called a simple gear train. In it all the gears axes remain fixed relative to the frame and each gear is on a separate shaft.

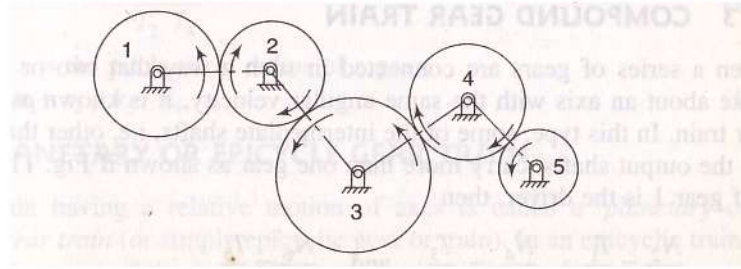

Figure - 50

In simple gear train,

1. two external gears of a pair always move in opposite direction and two in which one external gear meshing with another internal gear will move in same directions.
2. Speed ratio =  $\frac{\text{speed of driving wheel}}{\text{speed of driven wheel}}$

$$\text{Train ratio} = \frac{1}{\text{speed ratio}}$$

Let,

$T$  = number of teeth on a gear

$N$  = speed in rpm.

$$\frac{N_2}{N_1} = \frac{-T_1}{T_2}, \quad \frac{N_3}{N_2} = \frac{-T_2}{T_3}, \quad \frac{N_4}{N_3} = \frac{-T_3}{T_4}, \quad \frac{N_5}{N_4} = \frac{-T_4}{T_5}$$

$$\text{Train value} \frac{N_2}{N_1} \times \frac{N_3}{N_2} \times \frac{N_4}{N_3} \times \frac{N_5}{N_4} = \frac{-T_1}{T_2} \times \frac{-T_2}{T_3} \times \frac{-T_3}{T_4} \times \frac{-T_4}{T_5}$$

$$\frac{N_5}{N_1} = \frac{T_1}{T_5}$$

So intermediate gear have no effect on train values so they are called idle gears.

### Compound gear trains

When a series of gears is connected in such a way that two or more gears rotate about an axis with the same angular velocity, it is known as compound gear train.

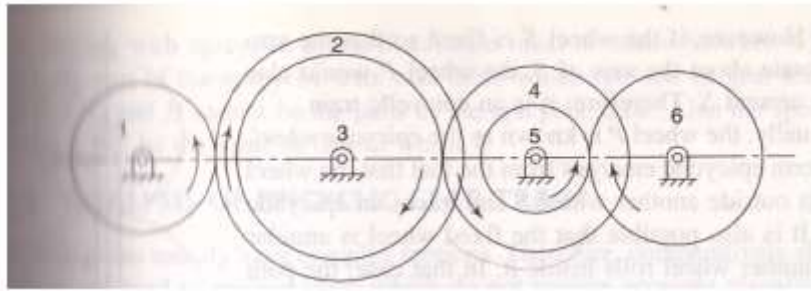

Figure - 51

$$\frac{N_2}{N_1} = \frac{-T_1}{T_2}, \quad \frac{N_4}{N_3} = \frac{-T_3}{T_4}, \quad \frac{N_6}{N_5} = \frac{-T_5}{T_6}, \quad N_2 = N_3, N_4 = N_5$$

$$\frac{N_2}{N_1} \times \frac{N_4}{N_3} \times \frac{N_6}{N_5} = \frac{-T_1}{T_2} \times \frac{-T_3}{T_4} \times \frac{-T_5}{T_6}$$

$$\frac{N_6}{N_1} = -\frac{T_1 \times T_3 \times T_5}{T_2 \times T_4 \times T_6}$$

### Reverted Gear Train

If the axis of first and last wheel of a compound gear coincide it is called a reverted gear train.

$$\frac{N_4}{N_1} = \frac{T_1 \times T_3}{T_2 \times T_4}$$

Also if  $r$  is the pitch circle radius of a gear

$$r_1 + r_2 = r_3 + r_4$$

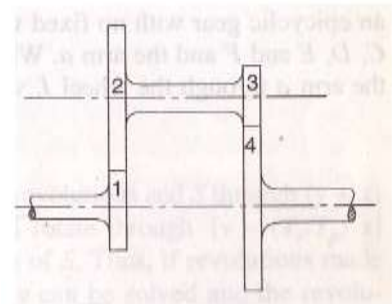

Figure - 52

### Planetary or Epicyclic gear train

In an epicyclic train, the axis of at least one of the gears also moves relative to the frame.

Epicyclic trains usually have complex motion. therefore comparatively simple methods are used to analyse them which do not require account visualization of the motion.



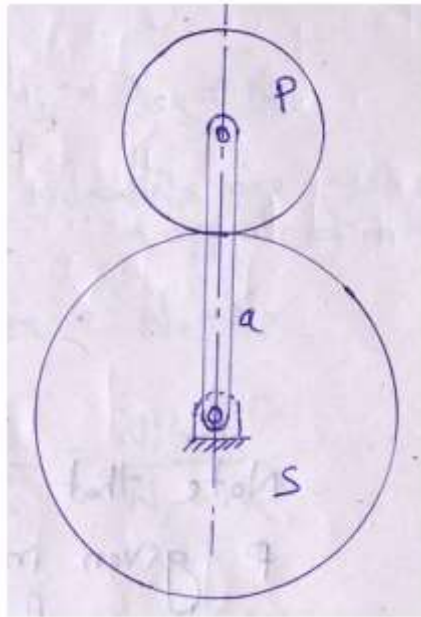

Figure - 53

Assume that the arm a is fixed. S turns through 'x' revolutions in the anti clock wise direction. Assume anti clock wise motion as +ve and clock wise motion is -ve.

Revolution made by a = 0

Revolution made by s = x

Revolution made by p =  $-\frac{T_s}{T_p} x$

Now, if mechanism is locked together and turned through a number of revolutions, the relative motions between a, s and p will not alter. Let the locked system is turned through y revolutions in the anti clockwise direction. The

Revolution made by a = y

Revolution made by s = y + x

Revolution made by P =  $y - \frac{T_s}{T_p} x$  (relative to fixed axis s)

Thus, if revolution made by any of the two elements are known, x and y can be solved and the revolutions made by the third or others can be determined.

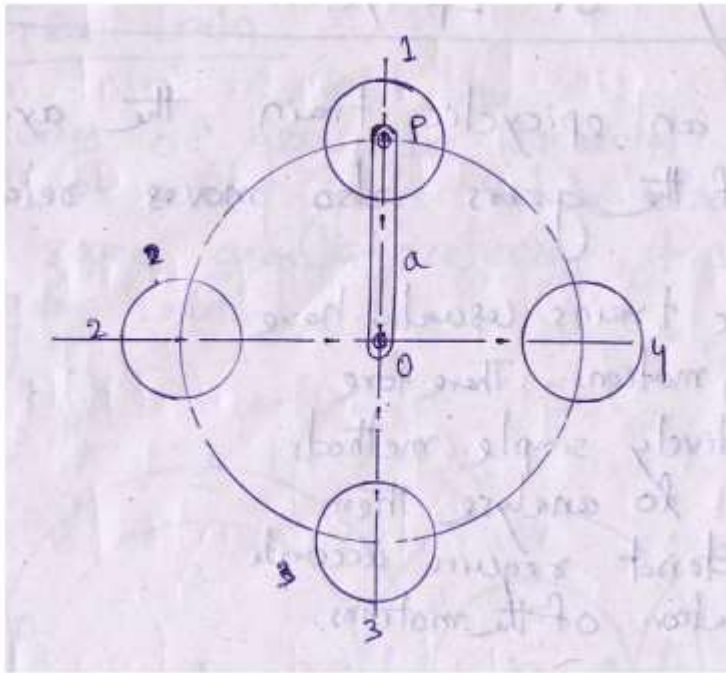

Figure - 54

Note that the number of revolution of the wheel P given in the 1<sup>st</sup> row is the number of revolutions in space or relative to fixed axis of s and not about its own axis.

It is shown that p rotates through one revolution as the arm turns through one revolution. However the rotation of P is in space of about own axis. Thus if the arm makes y revolutions about o the wheel p also rotates through y revolutions of p about its own axis can be obtained by subtracting the number of revolution of the arm from the total number of revolution so p.

Revolution of p about its own axis = to total revs about axis of arm – revs of the arm

$$= [y - \frac{T_s}{T_p} x] - y$$

$$= -\frac{T_s}{T_p} x$$

### Relative velocity method

Angular velocity of s = angular velocity of s relative to a + angular velocity of a

$$\omega_s = \omega_{sa} + \omega_a$$

or  $N_s = N_{sa} + N_a$

similarly  $N_p = -N_{pa} + N_a$  ( $N_s$  and  $N_p$  are to be in opposite direction)

$$N_{sa} = N_s - N_a \quad \text{and} \quad N_{pa} = N_a - N_p$$

$$\frac{N_{sa}}{N_{pa}} = \frac{N_s - N_a}{N_a - N_p} \quad \text{or} \quad \frac{T_p}{T_s} = \frac{N_s - N_a}{N_p - N_a}$$

### Torque in epicyclic trains

Torques are transmitted from one element to another when a geared system transmits power. Assume that all the wheels of a gear trains rotate at uniform speeds i.e. accelerations are not involved. Also each wheel is in equilibrium under the action of torques acting on it.

Let  $N_s$ ,  $N_p$ ,  $N_a$ , and  $N_A$  be the speed and  $T_s$ ,  $T_a$ ,  $T_p$  and  $T_A$  the external torque, transmitted by s, a, p and A respectively.

We have  $T = 0$

$$T_s + T_a + T_p + T_A = 0$$

Now s and a are connected to machinery outside the system and transmits external torque. The planet p is not connected to any external source

$$T_s + T_a + 0 + T_A = 0$$

$$T_s + T_a + T_A = 0$$

If A is fixed

Assume no losses in power transmission

$$\sum T\omega = 0$$

$$\sum TN = 0$$

$$T_s N_s + T_a N_a + T_A N_A = 0$$

$$T_s N_s + T_a N_a = 0$$

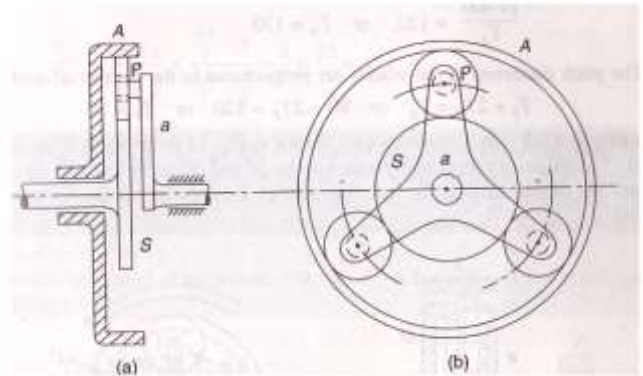

Figure - 55

### Brakes and dynamometers

#### Internal Expanding shoe brake

Figure shows internal shoe automobile brakes. It consists of two semi – circular shoes which are lined with a friction material such as ferodo. The shoes press against the inner

flange of the drum when the brakes are applied. Under normal running of the vehicle, the drum rotates freely as the outer diameter of the shoes is a little less than the internal diameter of the drum.

The actuating force  $F$  is usually applied by two equal diameter pistons in a common hydraulic cylinder and is applied equally in magnitude to each shoe. For the shown direction of the drum rotation, the left shoe is known as leading or forward shoe and right as the trailing or rear shoe.

Assuming that each shoe is rigid as compare to the friction surface, the pressure  $P$  at any to its distance  $l$  form the pivot

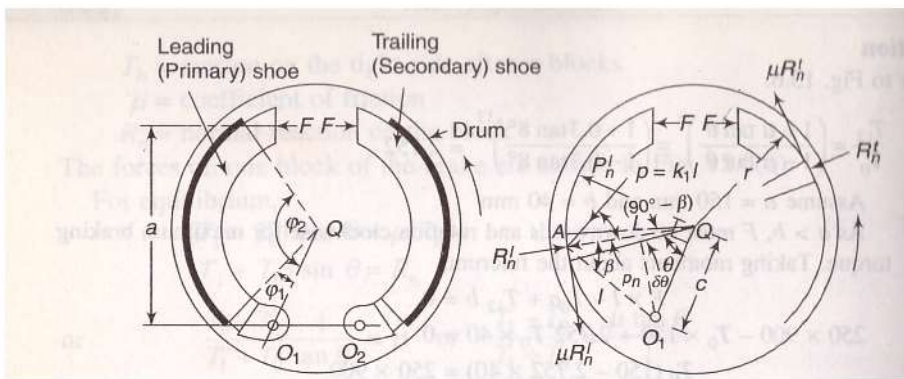

Figure - 56

Considering the leading shoe,

$$p \propto l = K_1 l \quad \text{where } K_1 \text{ is a constant}$$

The direction of  $p$  is perpendicular to  $OA$ .

$$\text{The normal pressure, } P_n = K_1 l \cos(90^\circ - \beta) = K_1 l \sin \beta$$

$$= K_1 C \sin \theta$$

$$= K_2 \sin \theta \quad \text{where } K_2 = K_1 C$$

$P_n$  is maximum when  $\theta = 90^\circ$

Let  $P_n^l =$  maximum intensity of normal pressure on the leading shoe.

$$P_{n \max} = P_n^l = K_2 \sin 90^\circ = K_2$$

$$P_n = P_n^l \sin \theta$$

Let  $w =$  width of brake lining,  $\mu =$  coefficient of friction

Consider a small element of brake lining on the leading shoe that makes an angle  $\delta\theta$  at the centre.

Normal reaction on the differential surface

$$R_n^l = \text{area} \times \text{pressure} = r \delta\theta w P_n = r \delta\theta w P_n^l \sin \theta$$

Taking moments about the fulcrum  $O_1$

$$Fa - \sum_{\phi_1}^{\phi_2} R_n^l C \sin \theta + \sum_{\phi_1}^{\phi_2} \mu R_n^l (r - C \cos \theta) = 0$$

$$\text{Where } \sum_{\phi_1}^{\phi_2} R_n^l C \sin \theta = \int_{\phi_1}^{\phi_2} rcwP_n^l \sin^2 \theta d\theta$$

$$= \int_{\phi_1}^{\phi_2} rcwP_n^l \frac{1}{2} (1 - \cos 2\theta) d\theta$$

$$= rcwP_n^l \frac{1}{2} \left( \theta - \frac{\sin 2\theta}{2} \right)_{\phi_1}^{\phi_2}$$

$$= \frac{rcwP_n^l}{4} (2\phi_2 - 2\phi_1 - \sin 2\phi_2 + \sin 2\phi_1)$$

And

$$\sum_{\phi_1}^{\phi_2} \mu R_n^l (r - C \cos \theta) = \int_{\phi_1}^{\phi_2} \mu r^2 w P_n^l \sin^2 \theta d\theta - \int_{\phi_1}^{\phi_2} rcwP_n^l \sin \theta \cos \theta d\theta$$

$$= \mu r^2 w P_n^l (-\cos \theta)_{\phi_1}^{\phi_2} - \int_{\phi_1}^{\phi_2} \mu rc w P_n^l \frac{1}{2} \sin 2\theta d\theta$$

$$= \mu r^2 w P_n^l (\cos \phi_1 - \cos \phi_2) - \mu rc w P_n^l \frac{1}{2} \left( \frac{-\cos 2\theta}{2} \right)_{\phi_1}^{\phi_2}$$

$$= \frac{\mu r w P_n^l}{4} [4r(\cos \phi_1 - \cos \phi_2) - c(\cos 2\phi_1 - \cos 2\phi_2)]$$

Taking moment about the fulcrum  $o_2$  for the trailing shoe

$$F_a - \sum_{\phi_1}^{\phi_2} R_n^t c \sin \theta - \sum_{\phi_1}^{\phi_2} \mu R_n^t (r - C \cos \theta) = 0$$

$$\text{Where } \sum_{\phi_1}^{\phi_2} R_n^t c \sin \theta = r c w R_n^t \frac{1}{4} [2\phi_2 - 2\phi_1 - \sin 2\phi_2 + \sin 2\phi_1]$$

and

$$\begin{aligned} & \sum_{\phi_1}^{\phi_2} \mu R_n^t (r - C \cos \theta) \\ &= \frac{\mu r w P_n^t}{4} [4r(\cos \phi_1 - \cos \phi_2) - c(\cos 2\phi_1 - \cos 2\phi_2)] \end{aligned}$$

Thus  $P_n^t$  and  $P_n^l$  the maximum pressure intensities on the leading and the trailing shoe, can be determined by

$$\begin{aligned} \text{Braking torque, } T_B &= \sum_{\phi_1}^{\phi_2} \mu R_n^t r + \sum_{\phi_1}^{\phi_2} \mu R_n^l r \\ &= \int_{\phi_1}^{\phi_2} \mu r^2 w P_n^l \sin \theta d\theta + \int_{\phi_1}^{\phi_2} \mu r^2 w P_n^t \sin \theta d\theta \\ &= \mu r^2 w (P_n^l + P_n^t) (-\cos \theta) \Big|_{\phi_1}^{\phi_2} \\ &= \mu r^2 w (P_n^l + P_n^t) (\cos \phi_1 - \cos \phi_2) \end{aligned}$$